

"OPTICAL CABLE CORPORATION (OCC)  
RESERVES THE RIGHT TO REVISE ANY  
ADAPTER ASSEMBLY SPECIFICATIONS."

REVISION HISTORY				
REV	SHT	DESCRIPTION	DATE	CHECKED
A	ALL	RELEASE NEW	3/11/14	JH

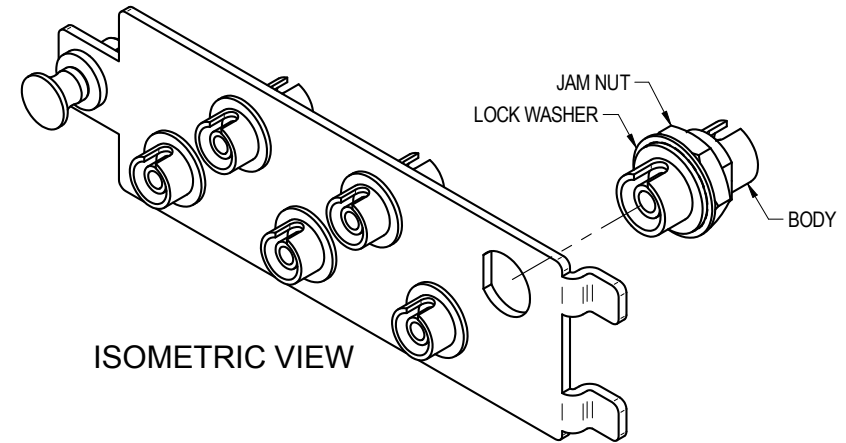
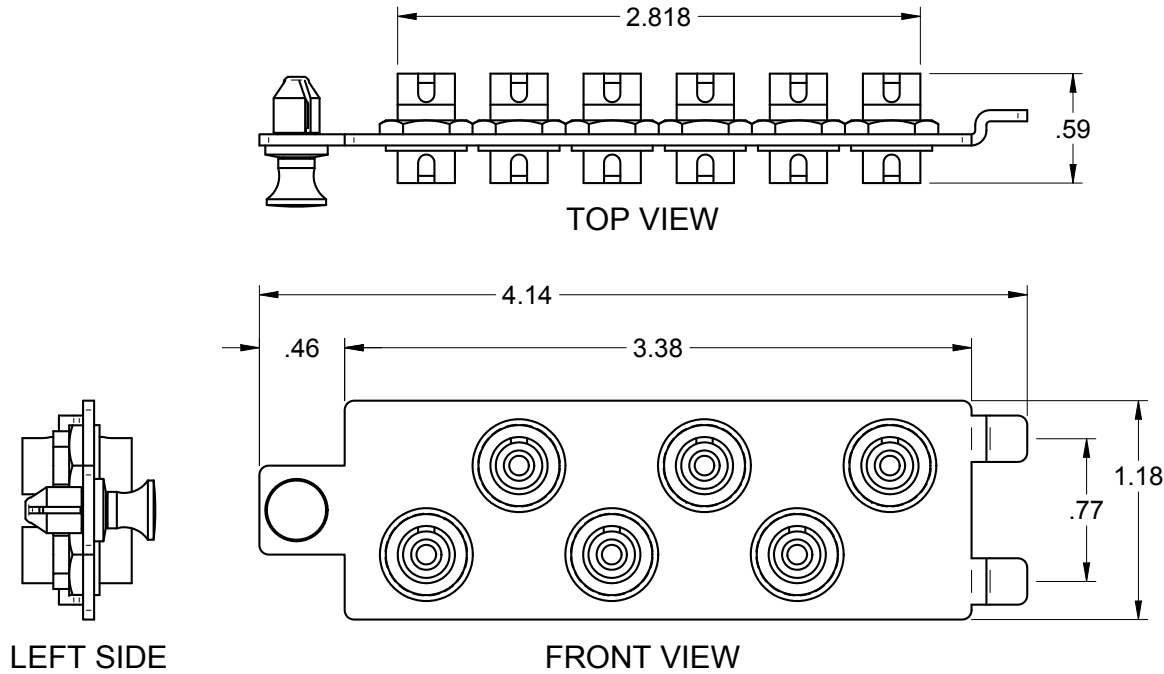

616FC/PCHD	ADAPTER PLATE ASSY, FCX6, SM/MM, 6P, HD, OCC
616FCHD	ADAPTER PLATE ASSY, FCX6, SM/MM, 6P, HD, OCC
616FCAPCHD	ADAPTER PLATE ASSY, FCX6, SM/APC, 6P, HD, OCC
616SMFCHD	ADAPTER PLATE ASSY, FCX6, SM, 6P, HD, OCC
616MMFCHD	ADAPTER PLATE ASSY, FCX6, MM, 6P, HD, OCC
616MMFCQHD	ADAPTER PLATE ASSY, FCX6, 50µm OM4, 6P, HD, OCC
616MMFCGHD	ADAPTER PLATE ASSY, FCX6, 50µm OM3, 6P, HD, OCC
OCC PART NO.	DESCRIPTION

NOTES: UNLESS OTHERWISE SPECIFIED.

- EACH ADAPTER PLATE ASSEMBLY IS SUPPLIED WITH COMPONENTS SHOWN.
- ADAPTER SPECIFICATIONS (MULTIMODE) 50µm, 50µm 10 GIG, 62.5µm  
INSERTION LOSS (AVERAGE): PHOSPHOR BRONZE SLEEVE: ≤ 0.3 dB MAX.  
SLEEVE/FERRULE WITHDRAWAL FORCE: 2.0N ~ 5.9N (200gf ~ 600gf)
- ADAPTER SPECIFICATIONS (SINGLEMODE)  
INSERTION LOSS (AVERAGE): ZIRCONIA CERAMIC SLEEVE: ≤ 0.2 dB MAX.  
SLEEVE/FERRULE WITHDRAWAL FORCE: 2.0N ~ 5.9N (200gf ~ 600gf)

**UNCONTROLLED COPY**

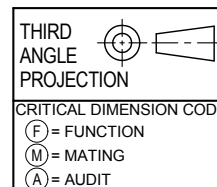

UNCONTROLLED COPY	
UNLESS OTHERWISE SPECIFIED DIMENSIONS ARE IN INCHES. TOLERANCES: FRACTIONS ±1/32" ANGLES ±1/2" 3 PLACE DECIMALS ±.005" 2 PLACE DECIMALS ±.01"	THIS DRAWING AND THE DESIGN SHOWN ARE THE PROPERTY OF OPTICAL CABLE CORPORATION AND MAY NOT BE USED AS THE BASIS FOR MANUFACTURE OR SALE WITHOUT SPECIFIC WRITTEN PERMISSION OF OPTICAL CABLE CORPORATION.
MATERIAL PLATE: 16 GAGE CRS (.060 THICK) ADAPTER: SEE BILL OF MATERIAL	FINISH PLATE: POWDER COAT BLACK PER OCC SPEC# 10002501
DRAWN D.A.HOLBERT	DATE 3/11/14
CHECKED S.PORACH	DATE 3/14/14
ENGINEER J.YANIK	DATE 3/11/14
APPROVED J.HOWE	DATE 3/14/14
PREVIOUS DWG	
NEXT DWG	FILENAME C111697A.DFT

 <b>OPTICAL CABLE CORPORATION</b>	5290 Concourse Drive Roanoke, VA 24019 Phone: 800-622-7711 Fax: 540-265-0724 www.occfiber.com	
	DWG TITLE <b>CUSTOMER DRAWING, ADAPTER PLATE ASSY, HD, FC, 6PORT, SM/MM, OCC</b>	
SIZE <b>B</b>	DWG NO. <b>C111697</b>	REV <b>A</b>
SCALE: <b>NONE</b>	SHEET <b>1 OF 1</b>	