

"OPTICAL CABLE CORPORATION (OCC)
RESERVES THE RIGHT TO REVISE ANY
SPlicing TRAY KIT SPECIFICATIONS."

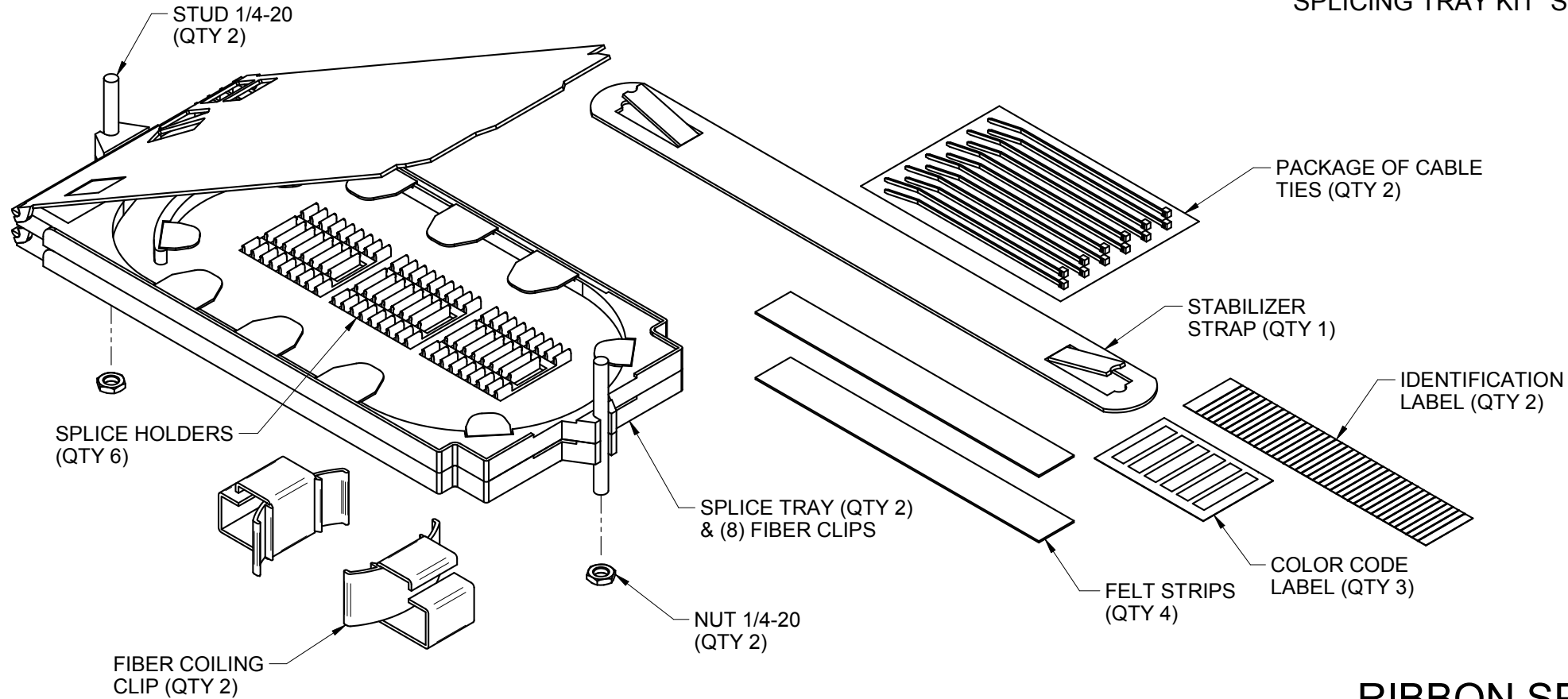

RIBBON SPLICE TRAY

NOTES: UNLESS OTHERWISE SPECIFIED.

1. SPlicing TRAY KIT IS PROVIDED WITH ITEMS SHOWN.

UNCONTROLLED COPY

THIRD ANGLE PROJECTION	
CRITICAL DIMENSION CODE	(F) = FUNCTION (M) = MATING (A) = AUDIT

UNLESS OTHERWISE SPECIFIED
DIMENSIONS ARE IN INCHES.
TOLERANCES: FRACTIONS $\pm 1/32"$
ANGLES $\pm 1/2"$
3 PLACE DECIMALS $\pm .005"$
2 PLACE DECIMALS $\pm .01"$

MATERIAL	SEE BILL OF MATERIAL
FINISH	SEE NOTES

RS1U2TR	SPlicing KIT, RTC/RTS, 1 UNIT, 2 TRAYS		
OCC PART NO.	DESCRIPTION		
DRAWN	D.A.HOLBERT	DATE	2/21/14
CHECKED	S.PORACH	DATE	2/21/14
ENGINEER	J.YANIK	DATE	2/21/14
APPROVED	J.HOWE	DATE	2/27/16
PREVIOUS DWG			
NEXT DWG	FILENAME C11178302B.dft	SCALE:	NONE
DWG TITLE		SIZE	REV
KIT, SPlicing TRAY, RTC/RTS, 1 UNIT, RS1U2TR		B	B
DWG NO.		SHEET	
C11178302		1 OF 1	



33 Superior Way
Swannanoa, NC 28778
Phone: 828-298-2260
Fax: 828-298-2487
www.occfiber.com