

UNCONTROLLED COPY

"OPTICAL CABLE CORPORATION (OCC) RESERVES THE RIGHT TO REVISE ANY AND ALL DESIGN SPECIFICATIONS."

REVISION HISTORY				
REV	SHT	DESCRIPTION	DATE	CHECKED
A	ALL	RELEASE NEW	08/30/17	NEW

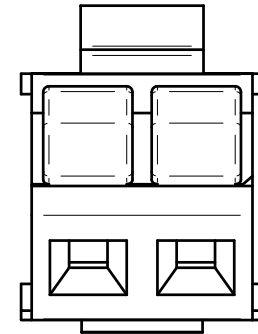
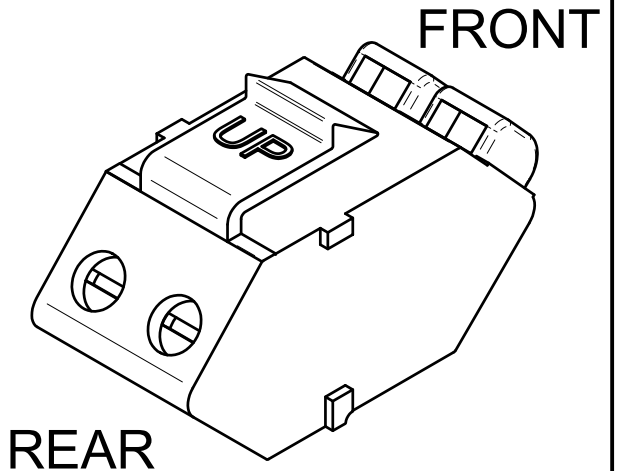
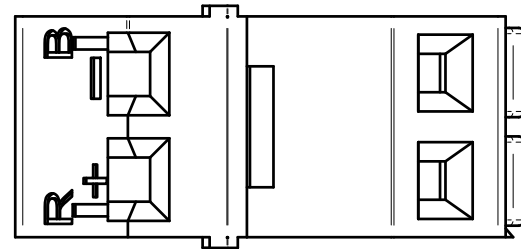
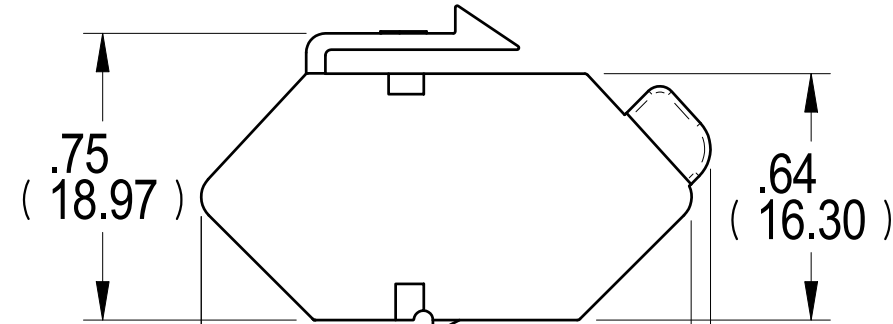
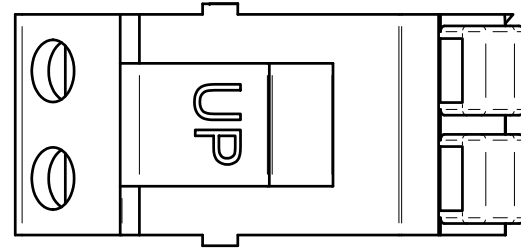
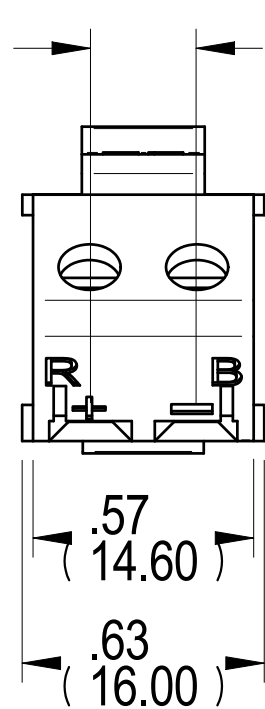
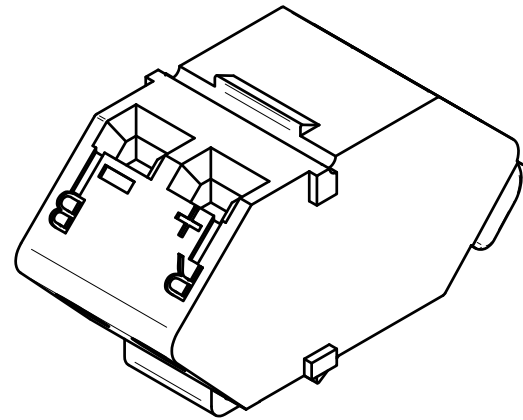
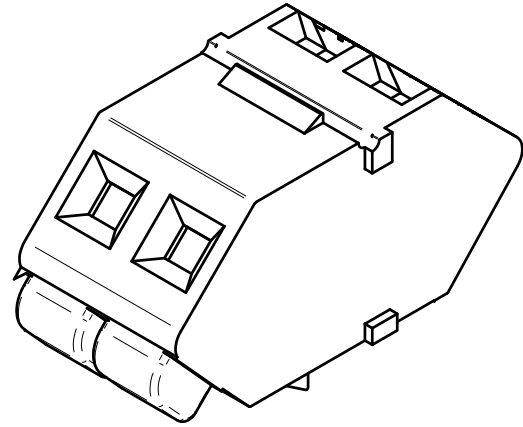

BLACK PUSH INSERT/REMOVE BUTTON

RED PUSH INSERT/REMOVE BUTTON

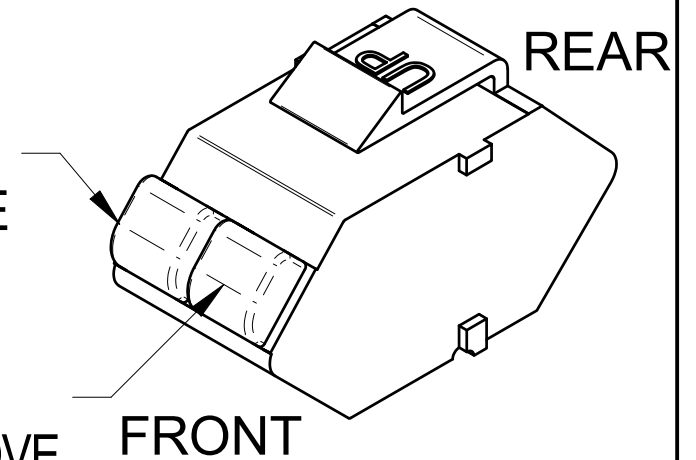

NOTES: UNLESS OTHERWISE SPECIFIED.

1. Rating: 300V, 15A
2. Insulation Withstand Voltage: 1500 VAC minimum
3. Insulation Resistance: 500 MΩ or more at 500VDC
Temperature range: -10°C - +60°C
Screw Torque: 4kg-cm
Wire gage: 24 - 14 AWG

UNCONTROLLED COPY

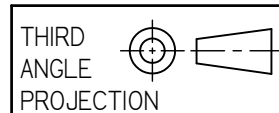

CRITICAL DIMENSION CODE
 (F) = FUNCTION
 (M) = MATING
 (A) = AUDIT

UNLESS OTHERWISE SPECIFIED DIMENSIONS ARE IN INCHES. TOLERANCES: FRACTIONS ±1/32" ANGLES ±1/2° 3 PLACE DECIMALS ±.005" 2 PLACE DECIMALS ±.01"

MATERIAL AS PURCHASED
 FINISH AS PURCHASED

THIS DRAWING AND THE DESIGN SHOWN ARE THE PROPERTY OF OPTICAL CABLE CORPORATION AND MAY NOT BE USED AS THE BASIS FOR MANUFACTURE OR SALE WITHOUT SPECIFIC WRITTEN PERMISSION OF OPTICAL CABLE CORPORATION.

DRAWN	J. Yanik	DATE	08/30/17
CHECKED		DATE	
ENGINEER	J. Yanik	DATE	08/30/17
APPROVED		DATE	
PREVIOUS DWG			
NEXT DWG		FILENAME	C112889A.DFT

AKDCPT01	AXCESS ADAPTER, KMJ, POWER PASS-THRU, OFFICE WHT
OCC PART NO.	DESCRIPTION

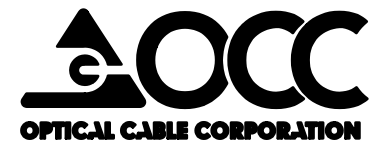

33 Superior Way
Swannanoa, NC 28778
Phone: 828-298-2260
Fax: 828-298-2487
www.occfiber.com

DWG TITLE		
ADAPTER, KMJ, 2-CONDUCTOR, POWER PASS-THRU, OFFICE WHT		
SIZE	DWG NO.	REV
B	C112889	A
SCALE:	NONE	SHEET 1 OF 1