

"OPTICAL CABLE CORPORATION (OCC)  
RESERVES THE RIGHT TO REVISE ANY  
AND ALL DESIGN SPECIFICATIONS."  
**UNCONTROLLED COPY**

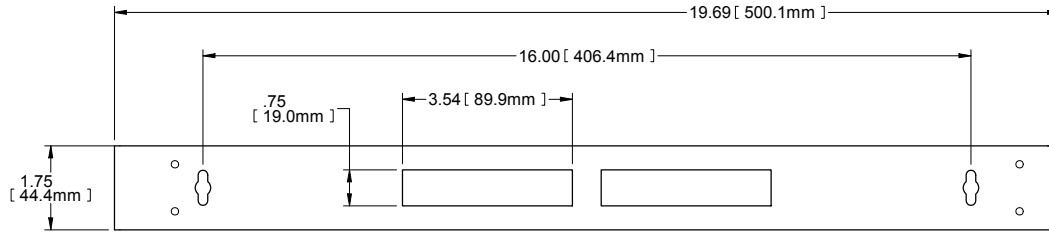

REAR VIEW

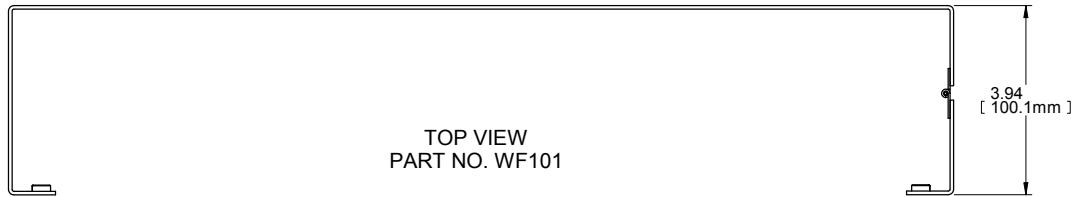

TOP VIEW  
PART NO. WF101

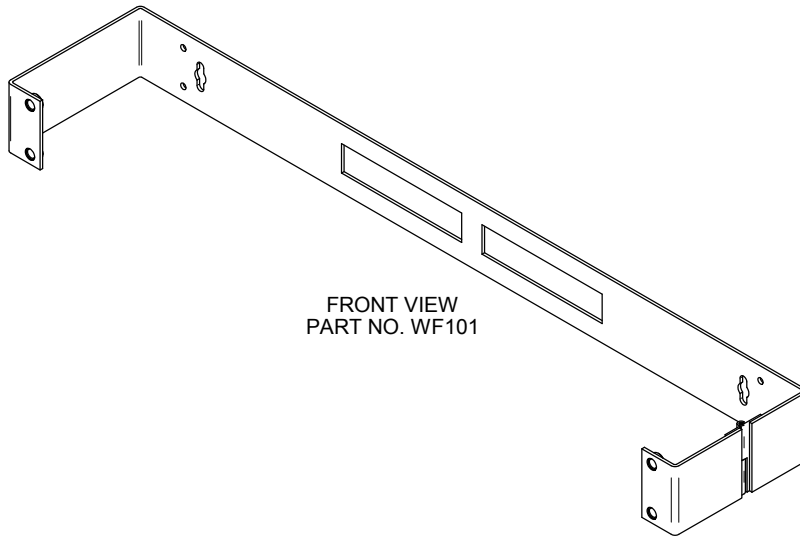

FRONT VIEW  
PART NO. WF101

UNLESS OTHERWISE SPECIFIED  
DIMENSIONS ARE IN INCHES  
TOLERANCES:  
FRACTIONS ±1/32"  
ANGLES ±1/2°  
3 PLACE DECIMALS ±.005"  
2 PLACE DECIMALS ±.01"

MATERIAL  
14 GA GALVANNEAL  
.075 THK  
FINISH  
PAINTED: BLACK  
POWDRCOAT WRINKLE  
OCC SPEC# 10002512

THIS DRAWING AND THE DESIGN SHOWN ARE THE  
PROPERTY OF OPTICAL CABLE CORPORATION AND  
MAY NOT BE USED AS THE BASIS FOR MANUFACTURE  
OR SALE WITHOUT SPECIFIC WRITTEN PERMISSION  
OF OPTICAL CABLE CORPORATION.

CHECKED	J.HOWE	DATE	6/23/07
ENGINEER	J.YANIK	DATE	12/19/05
APPROVED	D.INGLE	DATE	3/30/12
PREVIOUS DWG			
NEXT DWG			



33 Superior Way  
Swainsona, NC 28778  
Phone: 828-298-2260  
Fax: 828-298-2487  
www.occfiber.com

DWG TITLE		SIZE	DWG NO.	REV
1RU X 19" WALL MOUNT FRAME, 4" DEEP, WF101				
C300168		C	C300168	C

THIRD ANGLE PROJECTION  
CRITICAL DIMENSION CODE  
Ⓢ = FUNCTION  
Ⓜ = MATING  
ⓐ = AUDIT

WF101	FRAME, 19" WALL MOUNT, 4" DEEP, 1RU, BLACK						
OCC PART NO.	DESCRIPTION						
<table border="1"> <tr> <td>FILENAME</td> <td>C300168C.dft</td> <td>SCALE</td> <td>1:2</td> <td>SHEET</td> <td>1 OF 1</td> </tr> </table>		FILENAME	C300168C.dft	SCALE	1:2	SHEET	1 OF 1
FILENAME	C300168C.dft	SCALE	1:2	SHEET	1 OF 1		