

SPECS	PS115	PS120
VOLTAGE	120V	120V
CURRENT	15A	20A
VA per INPUT (LOAD CAPACITY)	1.4kW	1.9kW
FREQUENCY	50 / 60 HZ	50 / 60 HZ
OVER CURRENT PROTECTION	15A THERMAL BREAKER	20A THERMAL BREAKER
SWITCH	NO	NO
INDICATORS - LED	POWER (GREEN)	POWER (GREEN)
POWER CABLE WIRE GAUGE	14 / 3	12 / 3
POWER CABLE LENGTH	15 FT	15 FT
PLUG TYPE	NEMA 5-15P	NEMA 5-20P
RECEPTACLE / SOCKET	NEMA 5 - 15R	NEMA 5 - 20R
QUANTITY ON FRONT	2	2
QUANTITY ON REAR	10	10
QUANTITY PER BREAKER	12	12
STYLE	DUPLEX	DUPLEX
MAXIMUM OUTPUT PER RECEPTACLE / SOCKET	15A	20A
VOLTAGE PER RECEPTACLE / SOCKET	120V	120V
JOULE RATING	720	720
UL 1449 RATING (500A)	330V	330V
CLAMPING LEVEL	< 315 V	< 315 V
RESPONSE TIME	< 5 NANOSECONDS	< 5 NANOSECONDS
TECHNOLOGY USED	SUPER MOVS	SUPER MOVS
SURGE INDICATOR RED LED	YES	YES
CONTINUOUS OPERATING TEMPERATURE RANGE	10 - 45C / 50 - 113F	10 - 45C / 50 - 113F
HEAVY STEEL - BLACK POWDER COAT	YES	YES
CONFIGURATION	19 IN / 435 mm HORIZONTAL RACKMOUNT	19 IN / 435 mm HORIZONTAL RACKMOUNT
FLUSH MOUNT	YES	YES
MADE IN USA	YES	YES
CERTIFICATION / AGENCY APPROVALS	RoHS COMPLIANT	RoHS COMPLIANT
CERTIFICATION / AGENCY APPROVALS	UL & C - UL 60950	UL & C - UL 60950
CHASSIS DIMENSIONS (HxWxD)	1.72IN x 17 IN x 3.75IN	1.72IN x 17 IN x 3.75IN
SHIPPED WEIGHT	6 lbs (2.72kg)	7 lbs (3.18kg)

	PLUG	RECEPTACLE
PS115		
PS120		

"OPTICAL CABLE CORPORATION (OCC) RESERVES THE RIGHT TO REVISE ANY AND ALL SPECIFICATIONS."

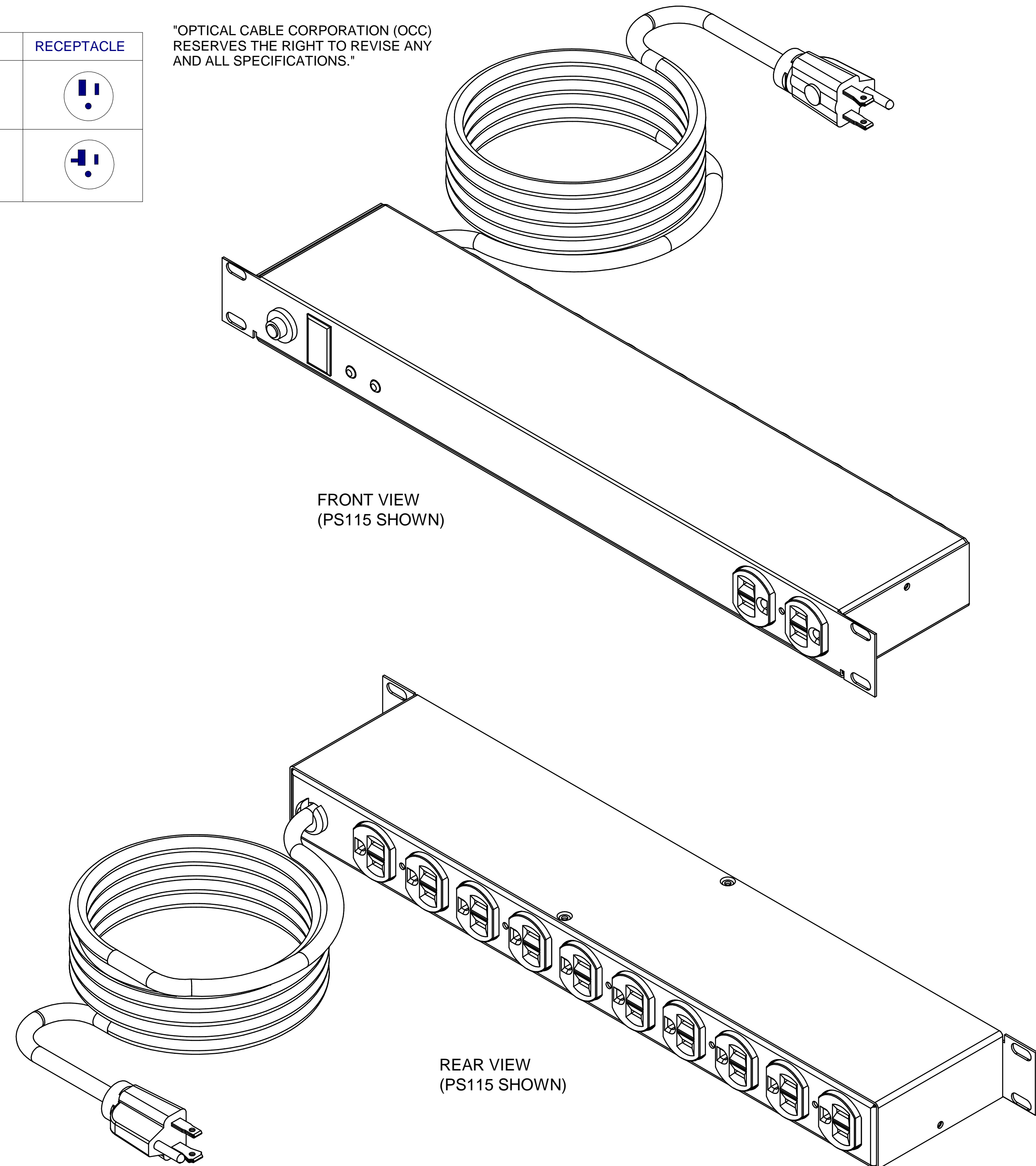

FRONT VIEW
(PS115 SHOWN)

REAR VIEW
(PS115 SHOWN)

PS120	20A-120V	BLACK
PS115	15A-120V	BLACK
OCC PART NO.	RATING	COLOR

OCC
OPTICAL CABLE CORPORATION
33 Superior Way
Swannanoa, NC 28778
Phone: 828-298-2260
Fax: 828-298-2487
www.occfiber.com

THIRD ANGLE PROJECTION
CRITICAL DIMENSION CODE
(F) = FUNCTION
(M) = MATING
(A) = AUDIT

MATERIAL	X	FINISH	X
CHECKED	J. YANIK	DATE	1/20/06
ENGINEER	J. YANIK	DATE	1/20/06
APPROVED	J. CALLOWAY	DATE	9/3/15
PREVIOUS DWG			
NEXT DWG			

DWG TITLE	POWER STRIP, 19" RACK MOUNT, W/SURGE		
SIZE	D	DWG NO.	C300177
SCALE	NONE	SHEET	1 OF 1
REV	A		

UNCONTROLLED COPY