

REV	DATE	DESCRIPTION	BY	CHKD
A	3/7/06	NEW	JV	

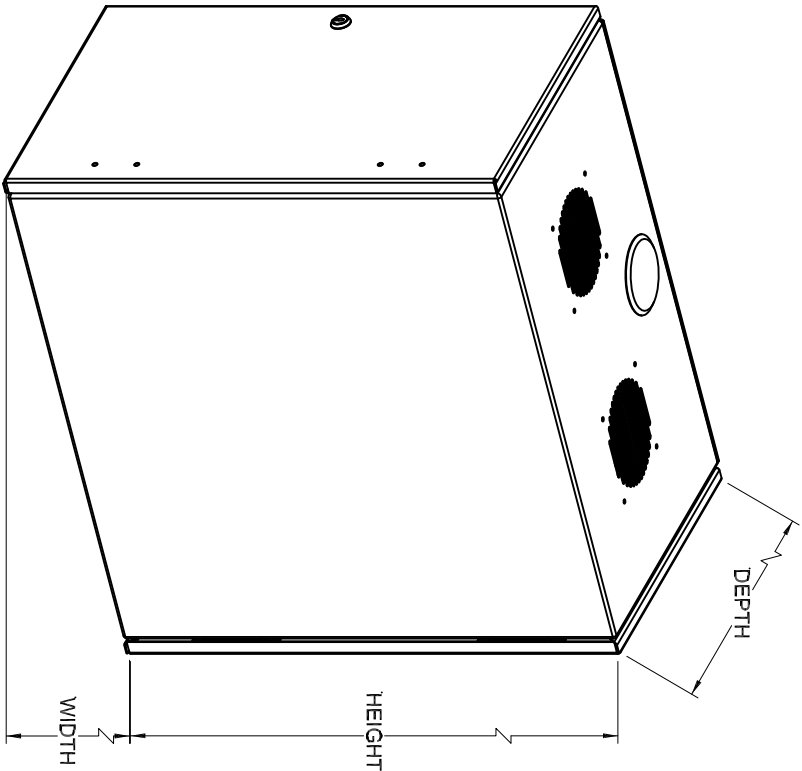
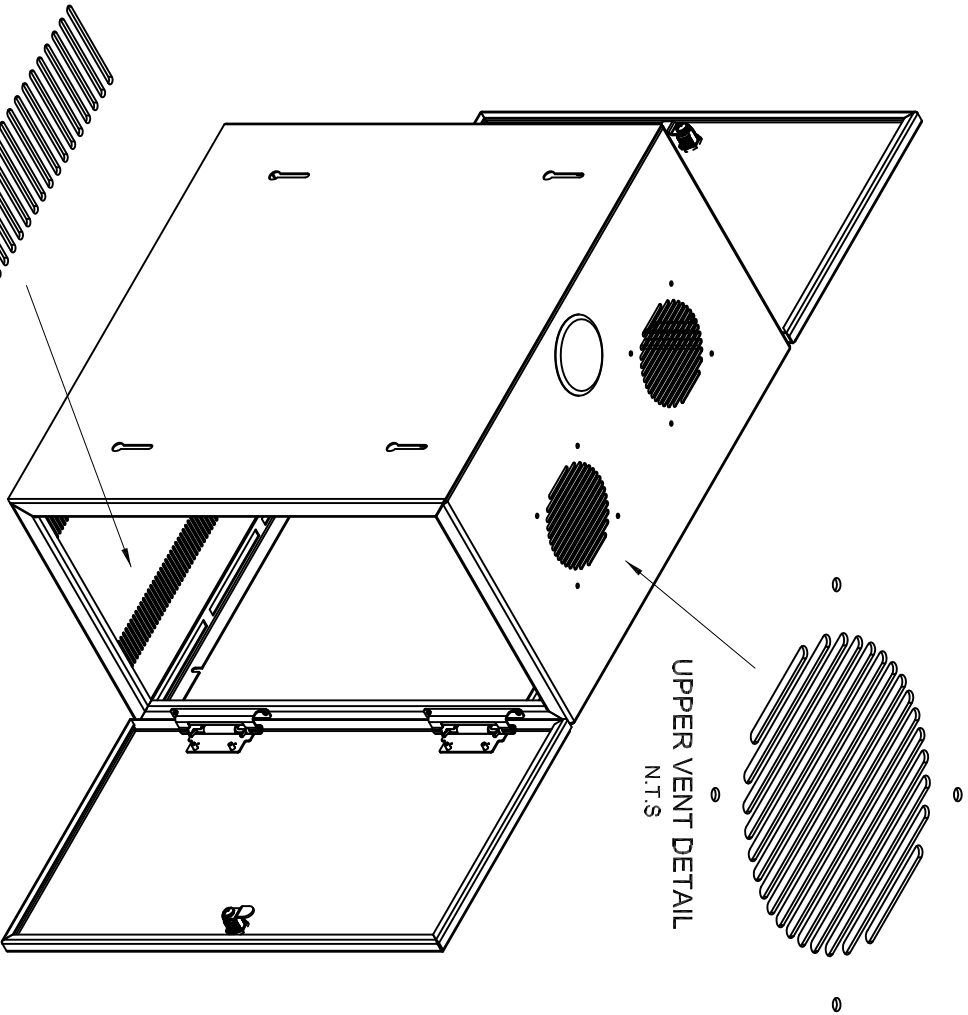

23" CABINET FRAME (CLOSED VIEW)

BOTTOM VENT DETAIL  
N.T.S

UPPER VENT DETAIL  
N.T.S

(OPENED VIEW)

NOTES: UNLESS OTHERWISE SPECIFIED,

1. DIMENSIONS ARE IN ENGLISH MEASUREMENTS.

UNCONTROLLED COPY

THIRD ANGLE PROJECTION		OCC PART NO.		HEIGHT		WIDTH		DEPTH		COLOR		RACK UNITS (RU)	
		CSM-7		22.5"		24"		13.5"		BLACK		7	RU
<small>UNLESS OTHERWISE SPECIFIED: DIMENSIONS ARE IN INCHES FRACTIONS ARE TO BE IN 16THS DECIMALS ARE TO BE IN 100THS DIMENSIONS AND TOLERANCES ARE TO BE AS SHOWN 1 PLACE DECIMALS = .005" MATERIAL SPECIFICATIONS: 18 GA. CSFS 080 THK FINISH: PAINTED BLACK POWDERCOAT WRINKLE PER SMP 10002512</small>													
<small>THIS DRAWING AND THE DESIGN IS OWNED BY THE PROPERTY OF AOC. NO REPRODUCTION, FACTURE OR SALE WITHOUT SPECIFIC WRITTEN PERMISSION OF ORIGINAL DATE CORPORATION.</small>													
DRAWN: K. MORRELL		DATE: 3/7/06		CHECKED: J. VANIK		DATE: 3/7/06		ENGINEER: J. VANIK		DATE: 3/7/06		APPROVED: R. B. SMITH	
DATE: 3/7/06		DATE: 3/7/06		DATE: 3/7/06		DATE: 3/7/06		DATE: 3/7/06		DATE: 3/7/06		DATE: 3/7/06	
NEXT DWG		FILENAME: C300217A.dwg		DWG TITLE: ENCLOSURE ASSY, SIDEWAYS MOUNT, 7RU		SIZE: C		DWG NO: C300217		REV: A		SHEET: 1 OF 1	