

REV		SHT	DESCRIPTION	DATE	ECN	CHECKED
A	ALL	RELEASE	NEW	4/11/02	NEW	RBS

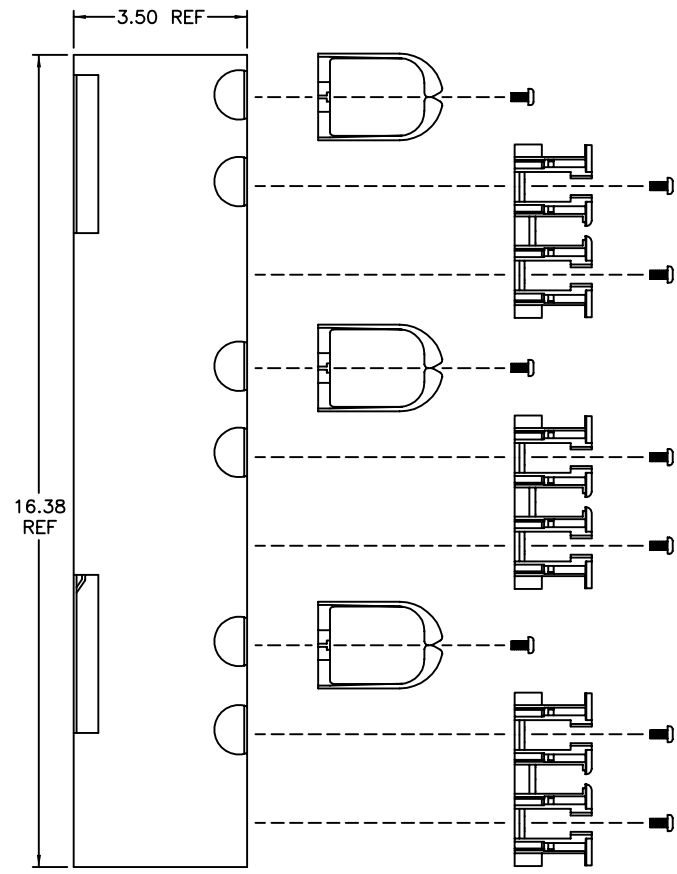

LEFT SIDE

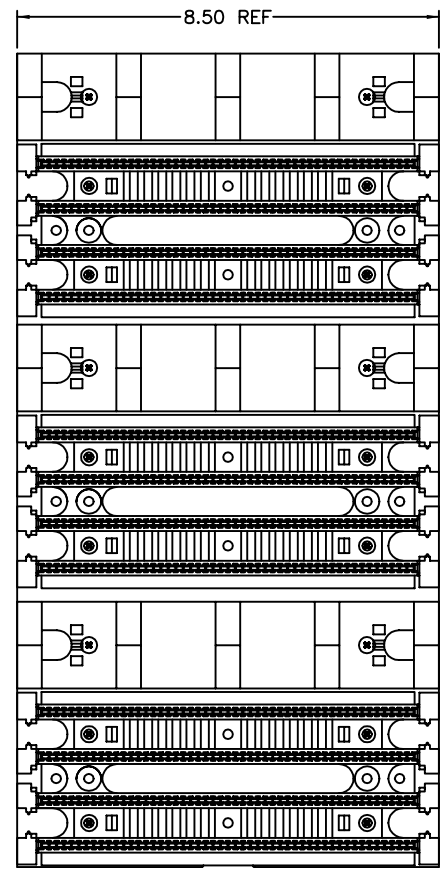

FRONT VIEW

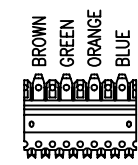

C4 CONNECTOR
65 QUANTITY

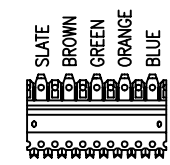

C5 CONNECTOR
13 QUANTITY

NOTE: SEE SHEET 2 FOR INSTRUCTIONS.

DCC300/110EFSTEXP		VERTICAL MGR, 110 TOWER, 300PR, EXPANSION, CAT5E	
OCC PART NO.		DESCRIPTION	
UNCONTROLLED COPY			
<small>UNLESS OTHERWISE SPECIFIED DIMENSIONS ARE IN INCHES TOLERANCES: FRACTIONS: ±1/32" ANGLES: ±1/2° 3 PLACE DECIMALS ±.005" 2 PLACE DECIMALS ±.01"</small>		<small>THIS DRAWING AND THE DESIGN SHOWN ARE THE PROPERTY OF OPTICAL CABLE CORPORATION AND MAY NOT BE USED AS THE BASIS FOR MANUFACTURE OR SALE WITHOUT SPECIFIC WRITTEN PERMISSION OF OPTICAL CABLE CORPORATION.</small>	
<small>CHECKED BY: R.B.SMITH ENGINEER: J.YANIK APPROVED: H.JOHNSON</small>		<small>DATE: 4/11/02 DATE: 4/22/02 DATE: 4/11/02</small>	
<small>MATERIAL: PANEL: CRS, 16 GAGE OTHER: POLYCARBONATE UL LISTED RATING 94V-0</small>		<small>FINISH: PANEL: POWDER COAT PAINTED BLACK</small>	
<small>THIRD ANGLE PROJECTION</small>		<small>DWG TITLE: VERTICAL MGR, 110 TOWER, 300PR, EXPANSION, CAT5E</small>	
<small>CRITICAL DIMENSION CODE: F = FUNCTION M = MATING A = AUDIT</small>		<small>SIZE: C DWG NO.: C105302 REV: A</small>	
<small>NEXT DWG:</small>		<small>FILENAME: C105302S1A.DWG SCALE: NONE SHEET: 1 OF 2</small>	



REV		SHT		DESCRIPTION		DATE	ECN	CHECKED
A	ALL	RELEASE	NEW			4/11/02	NEW	RBS

This information is intended to illustrate proper wiring procedures for the 100 pair, 110 wiring blocks. Step-by-step instructions given below should be followed for proper wiring installation.

Step 1
Configuring Horizontal & Backbone Cables to the Wiring Block

Remove the outer jacket of the horizontal or backbone cable up to 10 in. (254 mm) from the cable end. This allows individual pairs to be seated in the termination strip as shown in Figure 1. Cut-outs have been provided for optional cable access through the back of the wiring block.

The tip wire of pair-1, T1 (white), should be laced into the first or left-most slot. The ring wire of pair-1, R1 (blue), should be laced into the next slot to the right. Care should be taken to maintain twists as close as possible, 0.5 in. (13mm) or less, to the termination strip. Subsequent pairs should follow this same pattern always keeping the tip (white) wire to the left of the ring wire. No more than one wire should be seated into each slot. For convenience, every five pair have been designated by color coded notches.

After each pair has been laced into the termination strip, excess wire should be trimmed with the cutting edge of an impact tool.

Step 2
Seating the 110C-4 Connecting Blocks

Once each pair has been laced and trimmed, the 110C-4 connecting blocks are ready to be seated on the termination strip. Orientate the connecting block as shown in Figure 2 with the blue marking on the left (dark side down). Seat the connecting block using AT&T P/N 788J1 (comcode 102648839) 5-pair impact tool or equivalent.

Snap designation strips over the triangular hooks in the wiring block (Figure 1 on reverse). If cables are orientated according to Figure 1, wiring can be covered with designation strips for a neater appearance.

Step 3
Terminating Cross-Connect Wires to the Connecting Blocks

The 110C-4 connecting block is a double-ended, insulation displacement connector. It should be noted that only 22 through 26AWG (0.64-0.40mm) insulated wire should be used with this connector.

Once the connecting blocks have been seated and designation strips snapped into place, cross-connect wires can be terminated to the top of the connecting blocks. Arrange wires as shown in Figure 3 and terminate using AT&T P/N AT-8762-D (comcode 402024723) impact tool or equivalent. The AT&T 5-pair impact tool is not recommended for terminating wires to the top of the connecting blocks. Make sure the conductors are completely seated at the bottom of the wire slots and trim any excess wire using the cutting edge of the impact tool.

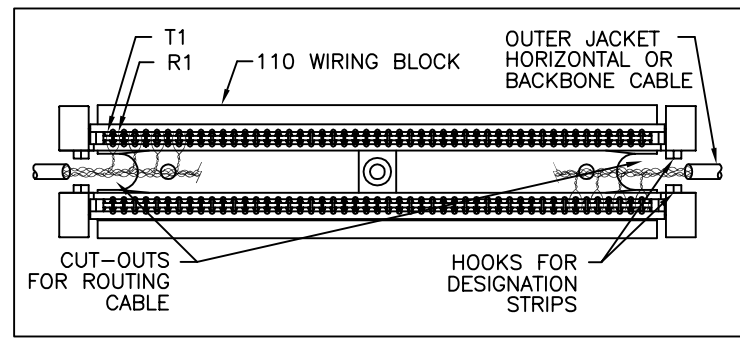

FIGURE 1 - CONFIGURE HORIZONTAL & BACKBONE CABLE TO THE 110 WIRING BLOCK (FOR SIMPLICITY, ONLY 4 TWISTED PAIRS ARE SHOWN FOR EACH CABLE)

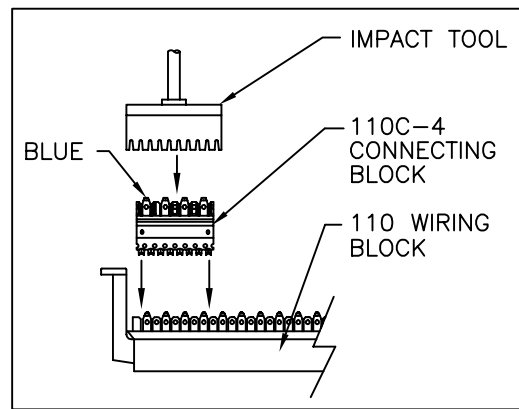

FIGURE 2 - SEATING THE 110C-4 CONNECTING BLOCK

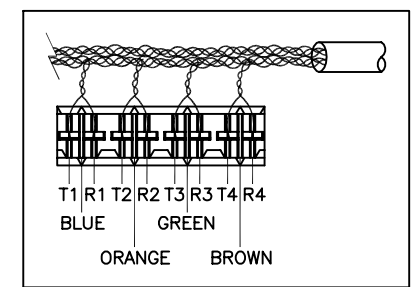



FIGURE 3 - TOP VIEW OF A 4-PAIR 110C-4 CONNECTING BLOCK

UNCONTROLLED COPY		 OPTICAL CABLE CORPORATION	5290 Concourse Drive Roanoke, VA 24019 Phone: 800-822-7711 Fax: 540-285-0724 www.occfiber.com	
UNLESS OTHERWISE SPECIFIED DIMENSIONS ARE IN INCHES TOLERANCES: FRACTIONS: ±1/32" ANGLES: ±1/2° 3 PLACE DECIMALS ±.005" 2 PLACE DECIMALS ±.01"			THIS DRAWING AND THE DESIGN SHOWN ARE THE PROPERTY OF OPTICAL CABLE CORPORATION AND MAY NOT BE USED AS THE BASIS FOR MANUFACTURE OR SALE WITHOUT SPECIFIC WRITTEN PERMISSION OF OPTICAL CABLE CORPORATION.	
THIRD ANGLE PROJECTION	MATERIAL PANEL: CRS, 16 GAGE OTHER: POLYCARBONATE UL LISTED RATING 94V-0	CHECKED BY: R.B.SMITH ENGINEER: J.YANIK	DATE: 4/11/02 DATE: 4/22/02	DWG TITLE VERTICAL MGR, 110 TOWER, 300PR, EXPANSION, CAT5E
	FINISH PANEL: POWDER COAT PAINTED BLACK	APPROVED: H.JOHNSON PREVIOUS DWG:	DATE: 10/1/10	
CRITICAL DIMENSION CODE Ⓢ = FUNCTION Ⓜ = MATING ⓐ = AUDIT		NEXT DWG:	FILENAME: C105302S2A.DWG	SCALE: NONE
				SHEET: 2 OF 2
				REV: A
				DWG NO.: C105302