

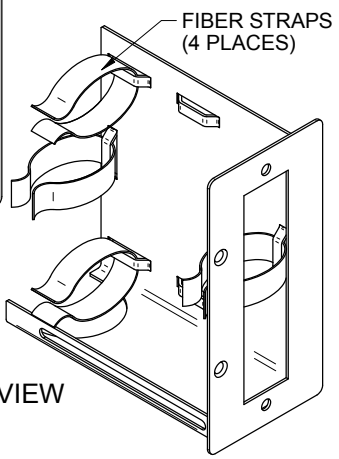

REVISION HISTORY		DATE	ECN	CHECKED
REV/SHT	DESCRIPTION			
A	ALL RELEASE NEW	5/15/12	NEW	JY

"OPTICAL CABLE CORPORATION (OCC) RESERVES THE RIGHT TO REVISE ANY AND ALL DESIGN SPECIFICATIONS."

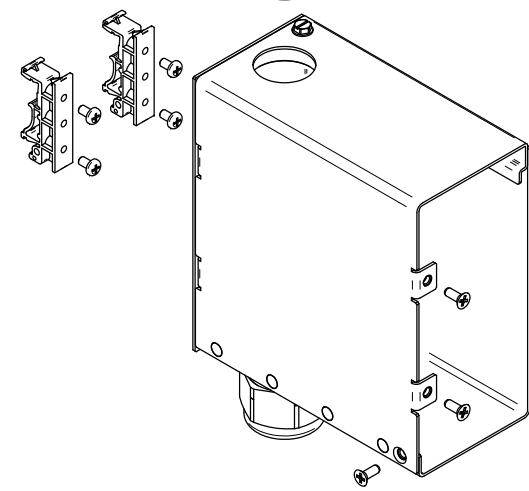
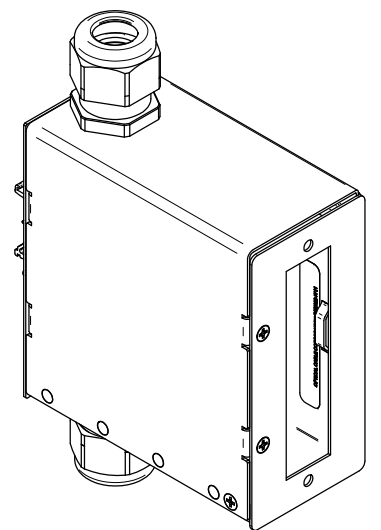
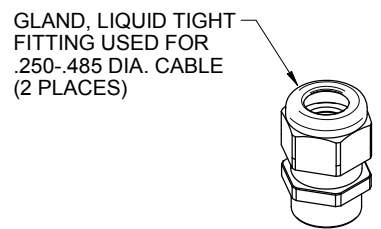
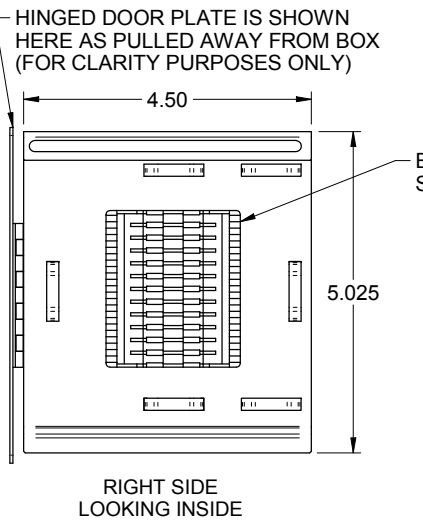
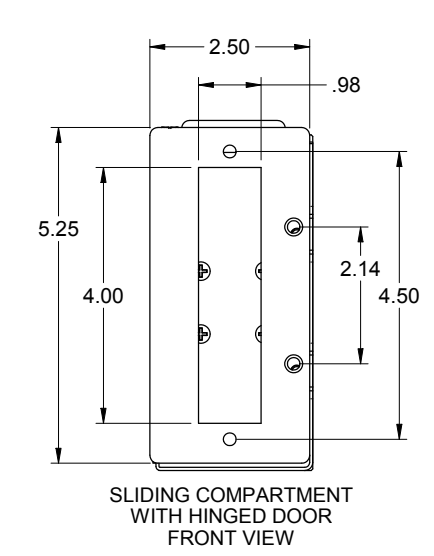
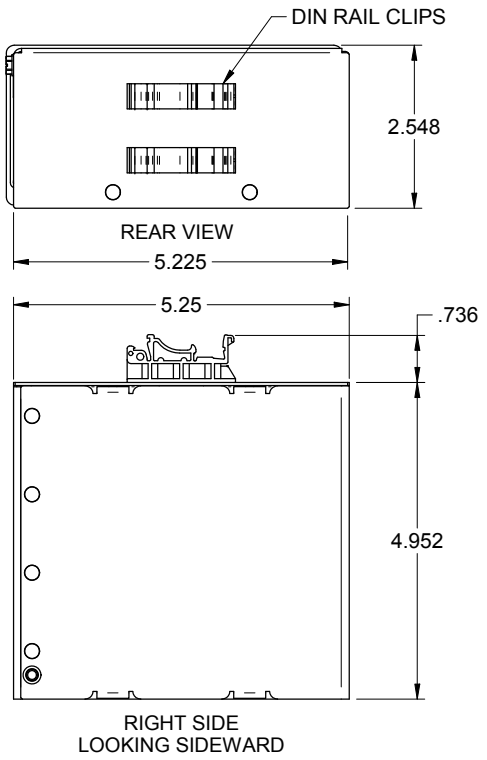
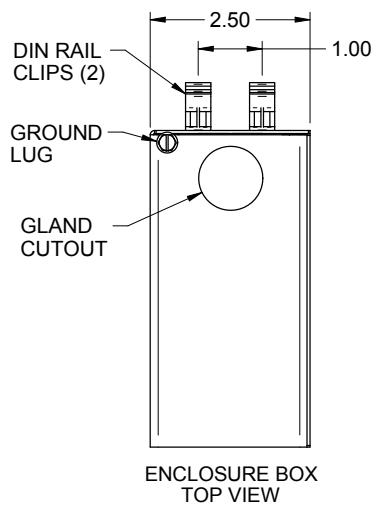
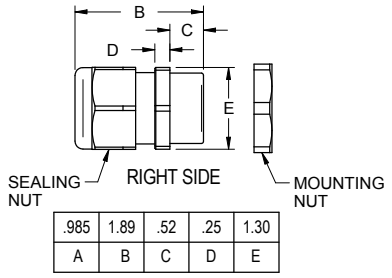

DTC1APG	CABINET, DIN RAIL, 1 ADAPTER PLATE, with GLAND	 <small>33 Superior Way Swannanoa, NC 28778 Phone: 828-298-2260 Fax: 828-298-2487 www.occfiber.com</small>
OCC PART NO.	DESCRIPTION	
<small>UNLESS OTHERWISE SPECIFIED DIMENSIONS ARE IN INCHES. TOLERANCES: FRACTIONS ±1/32 ANGLES ±1/2° 3 PLACE DECIMALS ±.005" 2 PLACE DECIMALS ±.01"</small>		<small>THIS DRAWING AND THE DESIGN SHOWN ARE THE PROPERTY OF OPTICAL CABLE CORPORATION AND MAY NOT BE USED AS THE BASIS FOR MANUFACTURE OR SALE WITHOUT SPECIFIC WRITTEN PERMISSION OF OPTICAL CABLE CORPORATION.</small>
<small>MATERIAL: OVER ALL BODY: BLACK POWDERCOAT PAINTED PER OCC SPEC# 100025</small>		
<small>THIRD ANGLE PROJECTION</small>		<small>DWG TITLE: DIN RAIL, FIBER, ADAPTER PLATE RECEPTACLE, DTC1APG</small>
<small>CRITICAL DIMENSION CODE</small>		<small>SIZE: C</small>
<small>(F) = FUNCTION</small>		<small>DWG NO. C112088</small>
<small>(M) = MATING</small>		<small>REV: A</small>
<small>(A) = AUDIT</small>		<small>SCALE: 1:1.5</small>
<small>PREVIOUS DWG</small>		<small>SHEET 1 OF 1</small>
<small>NEXT DWG</small>		

UNCONTROLLED COPY

