

**SPECIFICATIONS**

FEATURES/MATERIALS:

- CONSTRUCTED OF HIGH IMPACT SELF EXTINGUISHING, UL RATED 94V-0
- ACCOMMODATES ANY DOUBLE-GANG FACEPLATE

CODE & COMPLIANCE:

- UL LISTED

"OPTICAL CABLE CORPORATION (OCC) RESERVES THE RIGHT TO REVISE ANY AND ALL DESIGN SPECIFICATIONS."

**UNCONTROLLED COPY**

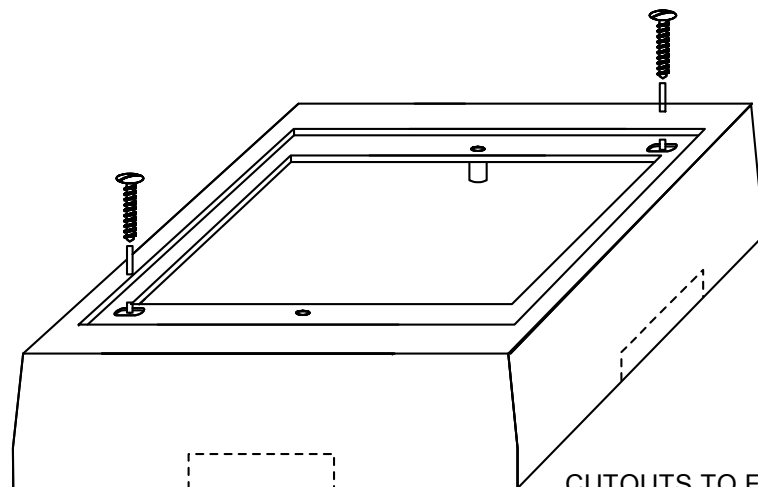

CUTOUTS TO FIT SURFACE CONDUIT

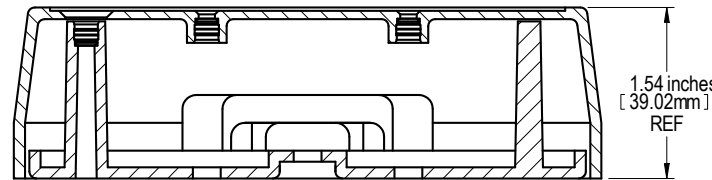
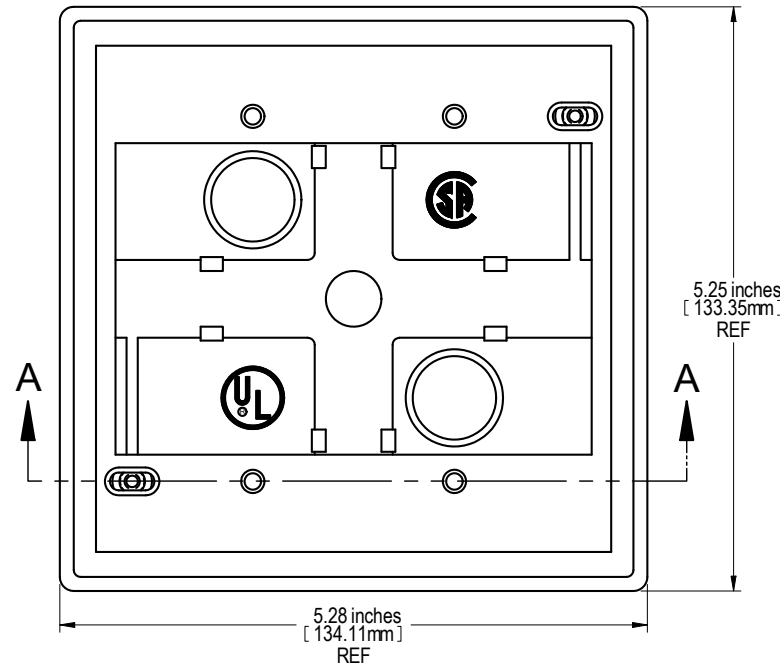
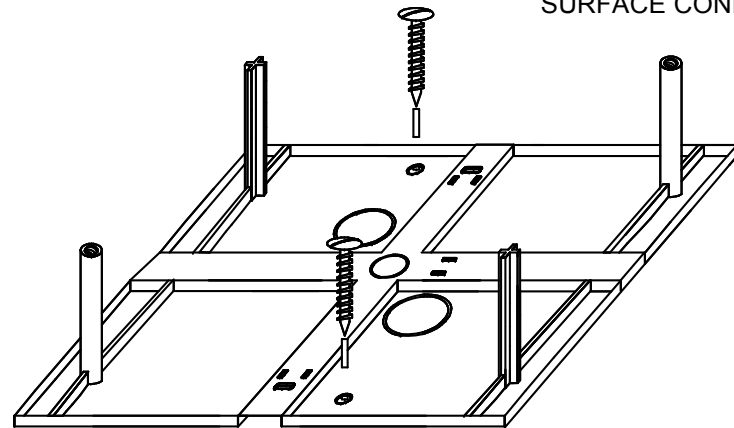

SECTION A-A

SMDG12	SURFACE MOUNT ENCLOSURE, DOUBLE GANG, BRIGHT WHITE
SMDG00	SURFACE MOUNT ENCLOSURE, DOUBLE GANG, ELEC. IVORY
OCC PART NUMBER	DESCRIPTION

**UNCONTROLLED COPY**

UNLESS OTHERWISE SPECIFIED DIMENSIONS ARE IN INCHES.  
 TOLERANCES: FRACTIONS ±1/32"  
 ANGLES ±1/2°  
 3 PLACE DECIMALS ±.005"  
 2 PLACE DECIMALS ±.01"



5290 Concourse Drive  
 Roanoke, VA 24019  
 Phone: 800-622-7711  
 Fax: 540-265-0724  
 www.occfiber.com

THIRD ANGLE PROJECTION

CRITICAL DIMENSION CODE  
 (F) = FUNCTION  
 (M) = MATING  
 (A) = AUDIT

MATERIAL  
 CATEGORY: THERMOPLASTIC  
 COLOR SPEC: SEE OCC  
 DRAWING #100004

FINISH  
 EXTERIOR: MT1055-3  
 FINE EDM

DRAWN	D.A.HOLBERT	DATE	7/30/01
CHECKED	J.HOWE	DATE	6/28/10
ENGINEER	J.YANIK	DATE	7/30/01
APPROVED	J.CALLOWAY	DATE	11/14/18
PREVIOUS DWG			
NEXT DWG			

DWG TITLE			CUSTOMER DRAWING, SURFACE MOUNT BOX, DOUBLE GANG, SMDGxx		
SIZE	DWG NO.	REV			
B	<b>C101124</b>	G			
FILENAME	C101124G.dft	SCALE:	NONE	SHEET	1 OF 1