

"OPTICAL CABLE CORPORATION (OCC)
RESERVES THE RIGHT TO REVISE ANY
AND ALL DESIGN SPECIFICATIONS."
UNCONTROLLED COPY

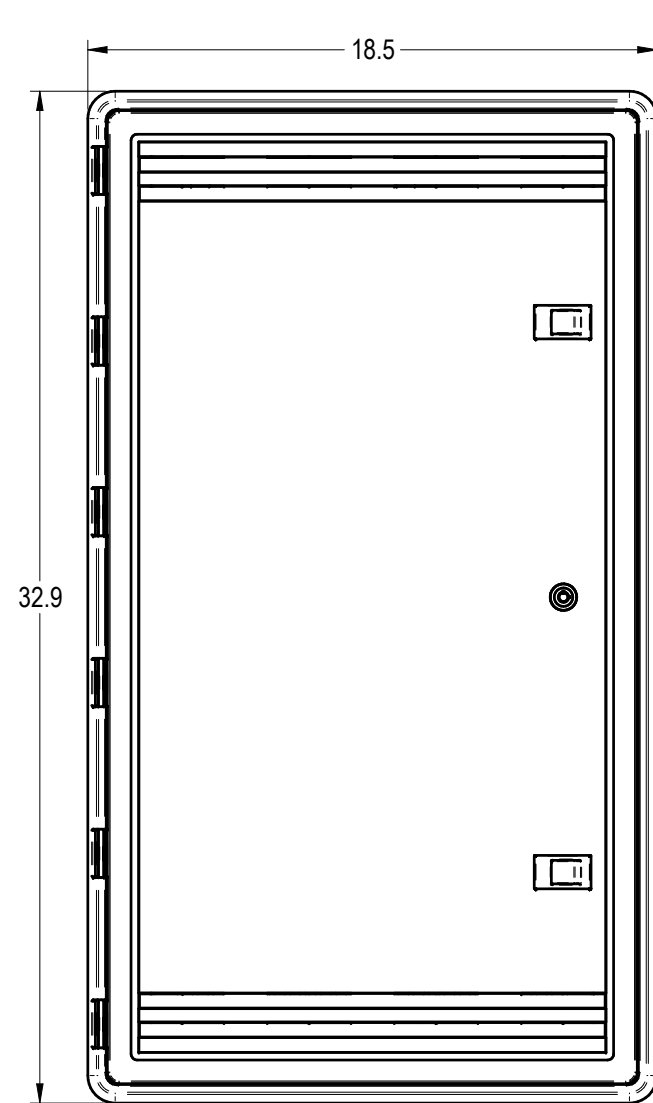

FRONT VIEW (LID ON)

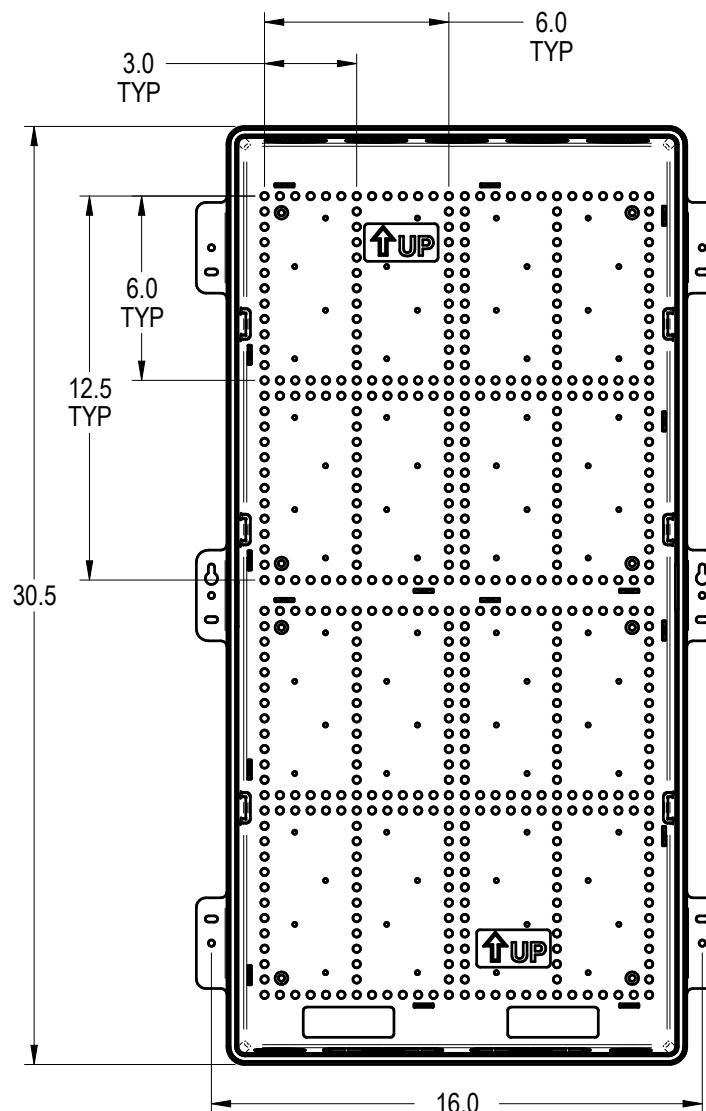

FRONT VIEW (LID OFF)

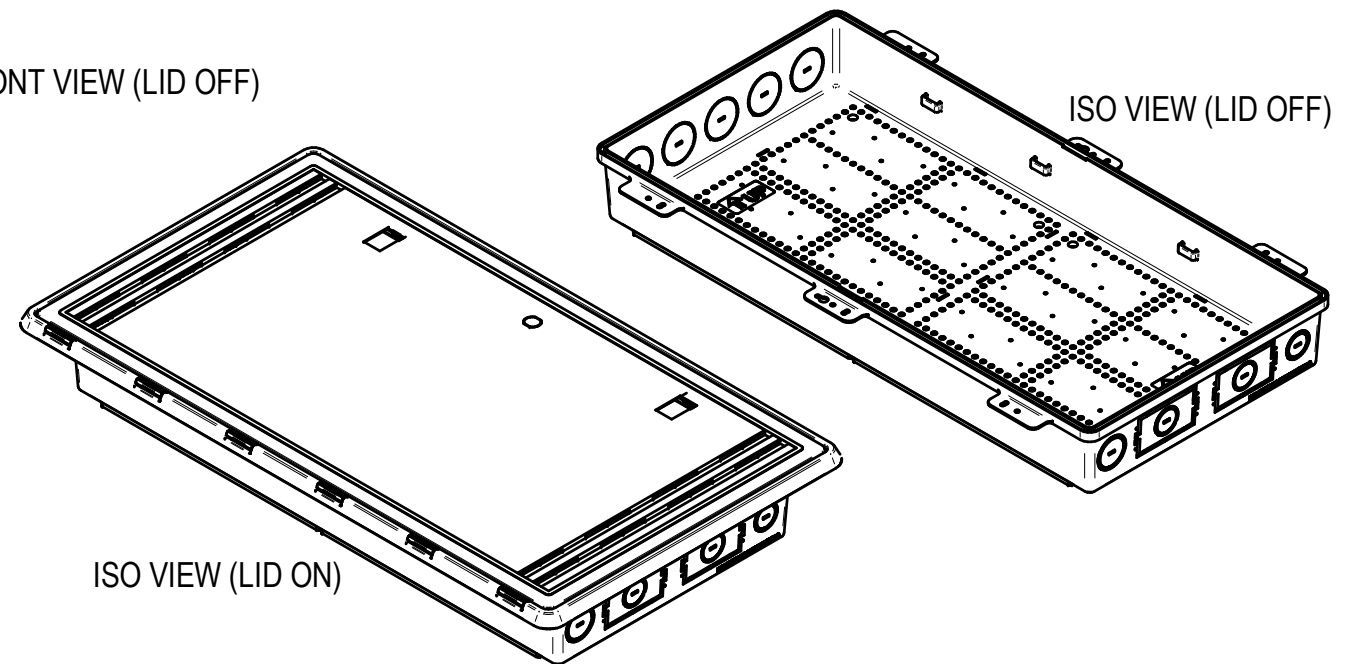

ISO VIEW (LID ON)

ISO VIEW (LID OFF)

DIMENSIONS
ENCLOSURE: 30.0" X 14.42" X 3.9"
COVER: 32.9" X 18.5" X .6" THK

MATERIAL
• UL94-V0 ABS PLASTIC CONSTRUCTION
• COLOR: WHITE

SAFETY
• UL 1863, COMMUNICATIONS CIRCUIT ACCESSORIES
• UL 2416, STANDARD FOR AUDIO/VIDEO, INFORMATION AND COMMUNICATION TECHNOLOGY EQUIPMENT CABINET, ENCLOSURE AND RACK SYSTEMS

FEATURES
• HINGED VENTED DOORS FOR HEAT DISSIPATION
• OPTIONAL LOCK (PURCHASED SEPERATELY)
• DOORS MAY BE REVERSE MOUNTED FOR LEFT OR RIGHT SWING

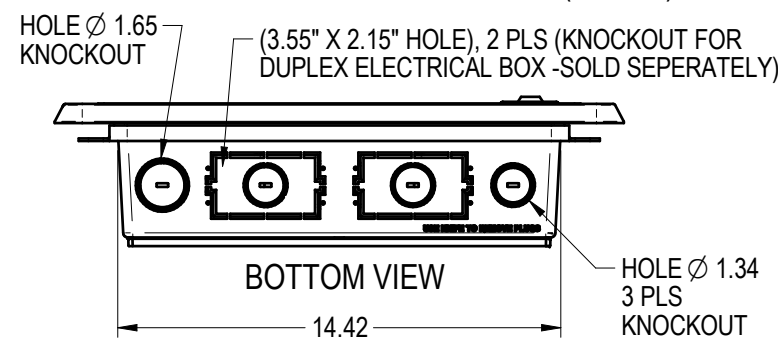

BOTTOM VIEW

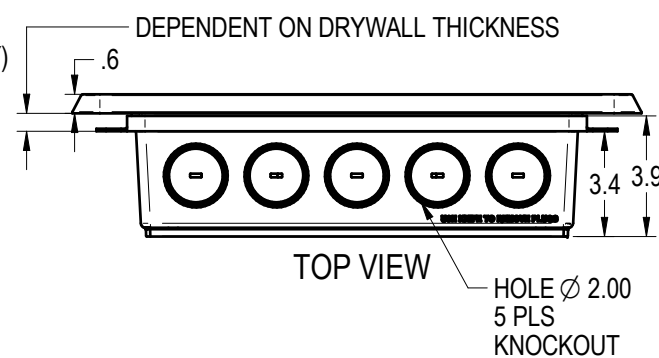

TOP VIEW

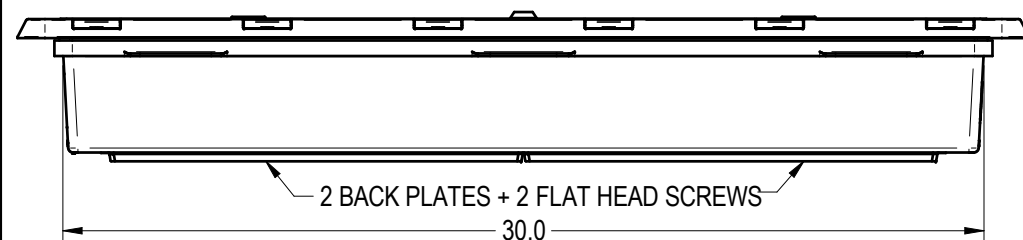

SIDE VIEW

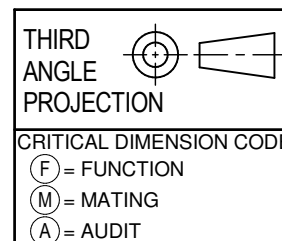

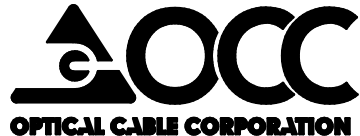
| | |
|---|--|
| MSDE30P | 30" PLASTIC ENCLOSURE WITH HINGED DOOR |
| OCC PART NUMBER | DESCRIPTION |
| UNCONTROLLED COPY | |
| UNLESS OTHERWISE SPECIFIED DIMENSIONS ARE IN INCHES. TOLERANCES: FRACTIONS ±1/32" ANGLES ±1/2° 3 PLACE DECIMALS ±.005" 2 PLACE DECIMALS ±.01" | THIS DRAWING AND THE DESIGN SHOWN ARE THE PROPERTY OF OPTICAL CABLE CORPORATION AND MAY NOT BE USED AS THE BASIS FOR MANUFACTURE OR SALE WITHOUT SPECIFIC WRITTEN PERMISSION OF OPTICAL CABLE CORPORATION. |
| MATERIAL UL94-V0 ABS PLASTIC (ENCLOSURE, DOOR, AND DOOR FRAME) |  <p>5290 Concourse Drive Roanoke, VA 24019 Phone: 800-622-7711 Fax: 540-265-0724 www.occfiber.com</p> |
| FINISH WHITE | |
| DRAWN C. MILLER | DATE 1/28/19 |
| CHECKED | DATE |
| ENGINEER C. MILLER | DATE 1/28/19 |
| APPROVED J. CALLOWAY | DATE 1/31/19 |
| PREVIOUS DWG | |
| NEXT DWG | FILENAME C113134A.dft |
| DWG TITLE | |
| MSDE30P ENCLOSURE | |
| SIZE B | DWG NO. C113134 |
| SCALE: NONE | SHEET 1 OF 1 |
| REV A | |