

"OPTICAL CABLE CORPORATION (OCC)
RESERVES THE RIGHT TO REVISE ANY
AND ALL DESIGN SPECIFICATIONS."

UNCONTROLLED COPY

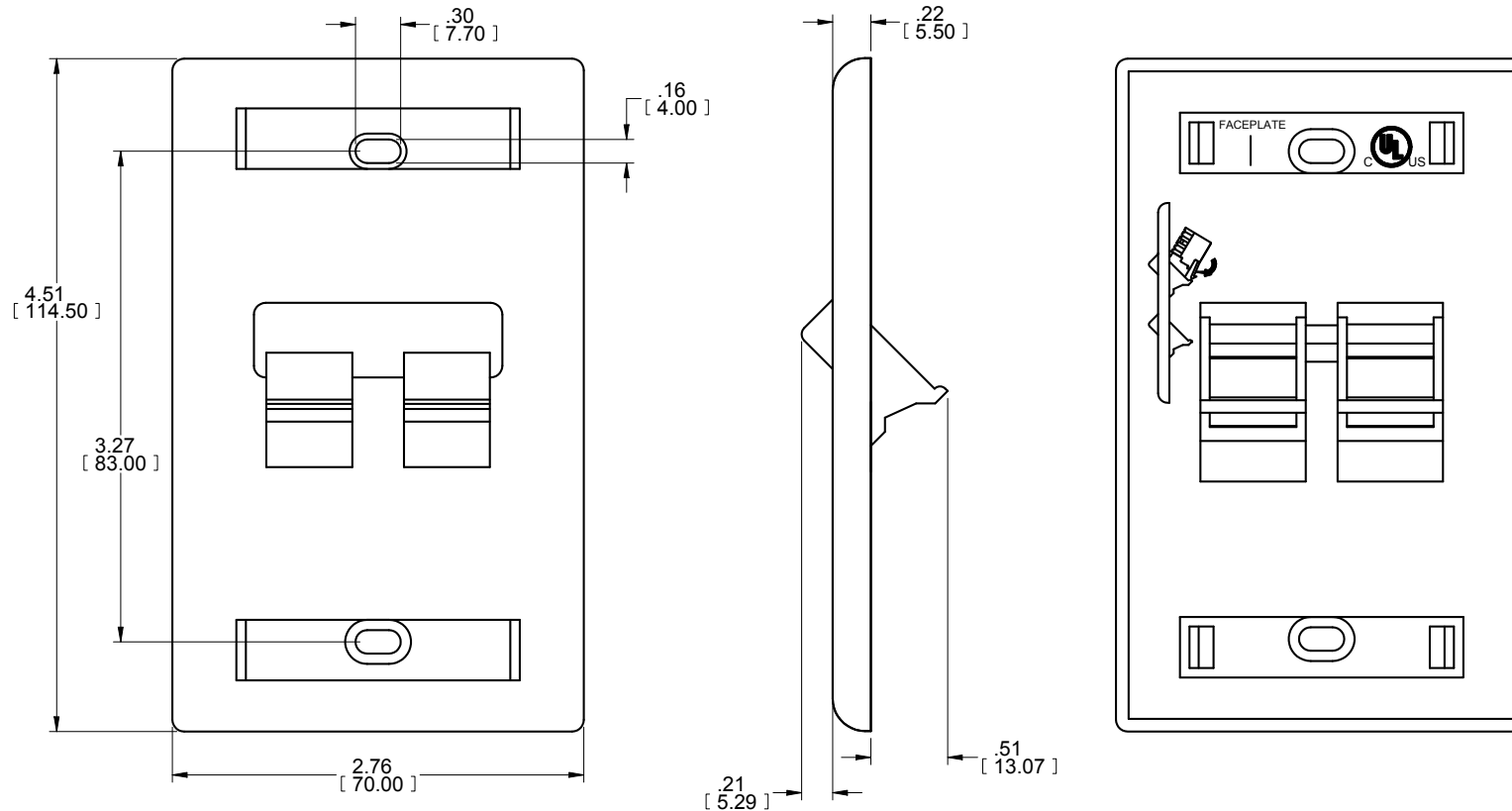

NOTES: UNLESS OTHERWISE SPECIFIED.

1. INCLUDES A HARDWARE KIT (2 ea. SCREWS) #6-32 X 7/8", TWO PAPER LABELS, AND 2 CLEAR BEZEL/COVERS.

2. "XX" IN PART NUMBER DESIGNATES "COLOR CODE."

SUFFIX	COLOR CODE
00	ELEC. IVORY
12	BRIGHT WHITE

3. ALTERNATE BRACKETED DIMENSIONS ARE IN MILLIMETERS.

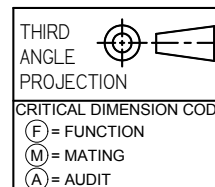

FPK02AXX	FACEPLATE, SG, ANGLED, KMJ x 2 PORT, "COLOR", COMMERCIAL			
OCC PART NO.	DESCRIPTION			
UNCONTROLLED COPY				
UNLESS OTHERWISE SPECIFIED DIMENSIONS ARE IN INCHES. TOLERANCES: FRACTIONS ±1/32" ANGLES ±1/2° 3 PLACE DECIMALS ±.005" 2 PLACE DECIMALS ±.01"	THIS DRAWING AND THE DESIGN SHOWN ARE THE PROPERTY OF OPTICAL CABLE CORPORATION AND MAY NOT BE USED AS THE BASIS FOR MANUFACTURE OR SALE WITHOUT SPECIFIC WRITTEN PERMISSION OF OPTICAL CABLE CORPORATION.		 33 Superior Way Swannanoa, NC 28778 Phone: 828-298-2260 Fax: 828-298-2487 www.occfiber.com	
	DRAWN	J. Yanik		DATE
MATERIAL	CHECKED	J. Howe	DATE	06/26/19
FLAME RETARDANT THERMOPLASTIC	ENGINEER	J. Yanik	DATE	06/26/19
UL LISTED RATING 94V-0	APPROVED	J. Calloway	DATE	06/26/19
FINISH	PREVIOUS DWG			
SEE NOTES; FOR COLOR	NEXT DWG			
	FILENAME	C:113279A.dft	SCALE:	NONE
			SHEET	1 OF 1
	DWG TITLE	FACEPLATE, SNG GNG, ANGLED, KMJ x 2 ID WINDOWS		REV
	SIZE	B	DWG NO.	C113279
				A