

"OPTICAL CABLE CORPORATION (OCC)
RESERVES THE RIGHT TO REVISE ANY
AND ALL DESIGN SPECIFICATIONS."
UNCONTROLLED COPY

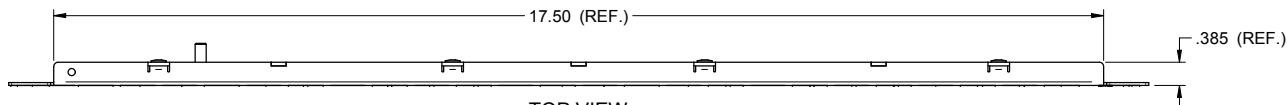

TOP VIEW

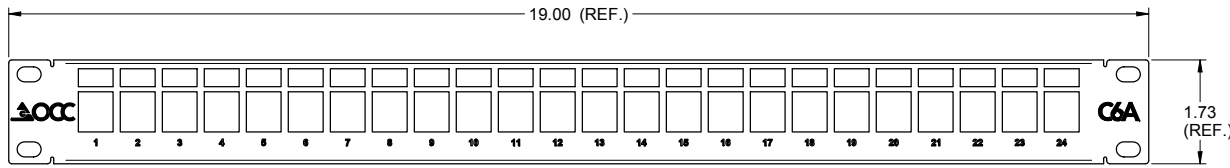

FRONT VIEW
AK24STP6A

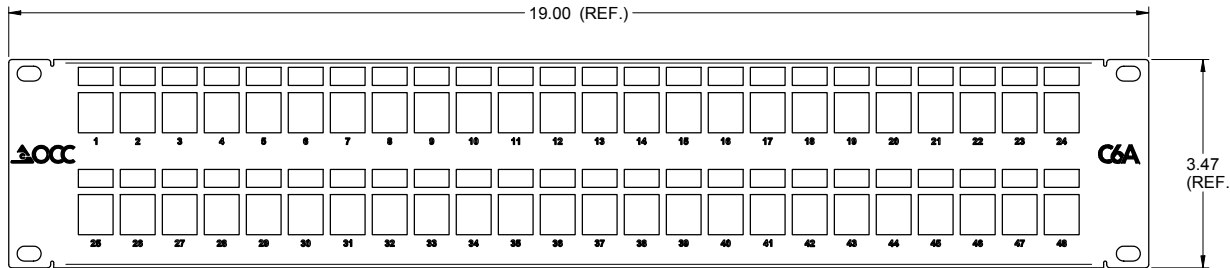

FRONT VIEW
AK48STP6A

APPLICATIONS:

- FOR 10GBASE-T APPLICATIONS

MATERIALS:

- PANEL: BLACK POWDER COAT, 16 AWG STEEL
- CABLE MANAGEMENT BARS, BLACK
POWDER COAT, 16 AWG STEEL

KIT INCLUDES THE FOLLOWING:

- 80" BONDING JUMPER
- (4) BLACK 12-24 PAN HEAD SCREWS
- CABLE MANAGEMENT BAR(S)
FOR AK24STP6A: QTY 1
FOR AK48STP6A: QTY 2
* KMJ JACKS SOLD SEPARATELY
- ACCOMMODATES K6AS (SHIELDED)
or K6Axx (UNSHIELDED) CAT6A JACKS

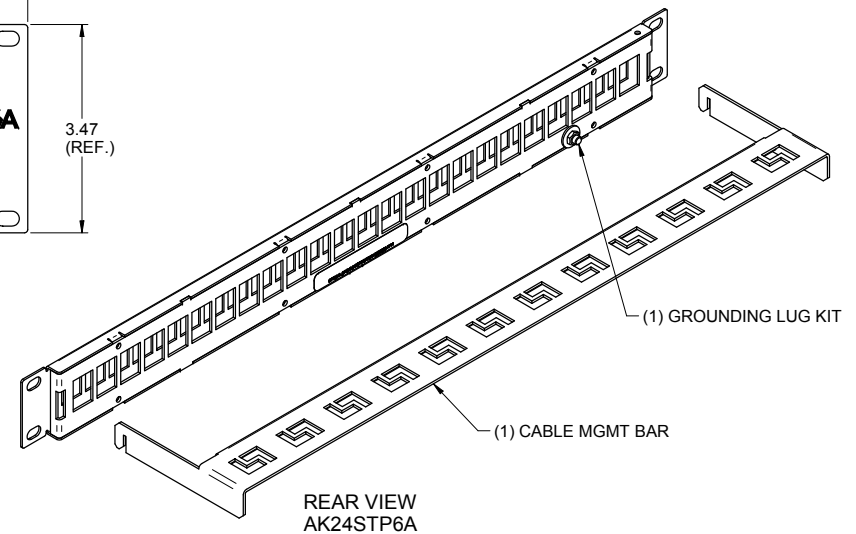

REAR VIEW
AK24STP6A

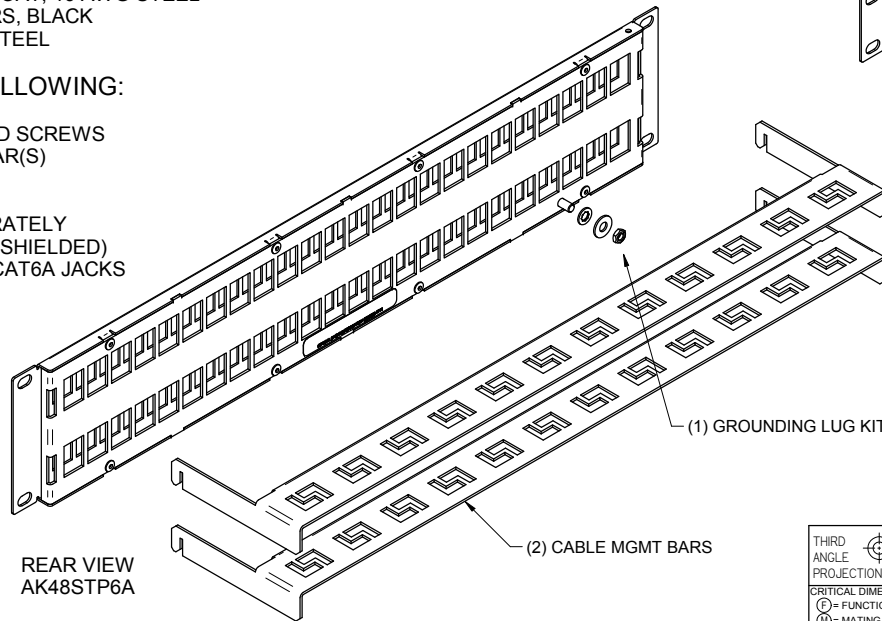

REAR VIEW
AK48STP6A

| AK48STP6A | ASSY, PATCH PANEL, 48 PORT, KMJ, SHIELDED, C6A, UNLOADED |
|--|--|
| AK24STP6A | ASSY, PATCH PANEL, 24 PORT, KMJ, SHIELDED, C6A, UNLOADED |
| OCC PART NUMBER | DESCRIPTION |
| <small>UNLESS OTHERWISE SPECIFIED THIS DRAWING AND THE DESIGN SHOWN ARE THE PROPERTY OF OPTICAL CABLE CORPORATION AND MAY NOT BE USED AS THE BASIS FOR MANUFACTURE OR SALE WITHOUT SPECIFIC WRITTEN PERMISSION OF OPTICAL CABLE CORPORATION.</small> | |
| <small>DRAWN D.A.HOLBERT DATE 4/7/17</small> | |
| <small>CHECKED J.HOWE DATE 4/17/17</small> | |
| <small>ENGINEER J.YANIK DATE 4/7/17</small> | |
| <small>APPROVED D.INGLE DATE 4/19/17</small> | |
| <small>PREVIOUS DWG</small> | |
| <small>NEXT DWG</small> | |
| <small>FILENAME C112758.dft</small> | |
| <small>SCALE: NONE</small> | |
| <small>SHEET 1 OF 1</small> | |
| <small>33 Superior Way Swannanoa, NC 28778 Phone: 828-298-2260 Fax: 828-298-2487 www.occfiber.com</small> | |
| | |
| DWG TITLE ASSEMBLY, PATCH PANEL, 24/48 PORT, SHIELDED, KMJ | |
| SIZE C | DWG NO. C112758 |
| REV A | |

THIRD ANGLE PROJECTION

CRITICAL DIMENSION CODE

(F) = FUNCTION

(M) = MATING

(A) = AUDIT