

"OPTICAL CABLE CORPORATION (OCC)
RESERVES THE RIGHT TO REVISE ANY
AND ALL DESIGN SPECIFICATIONS."

UNCONTROLLED COPY

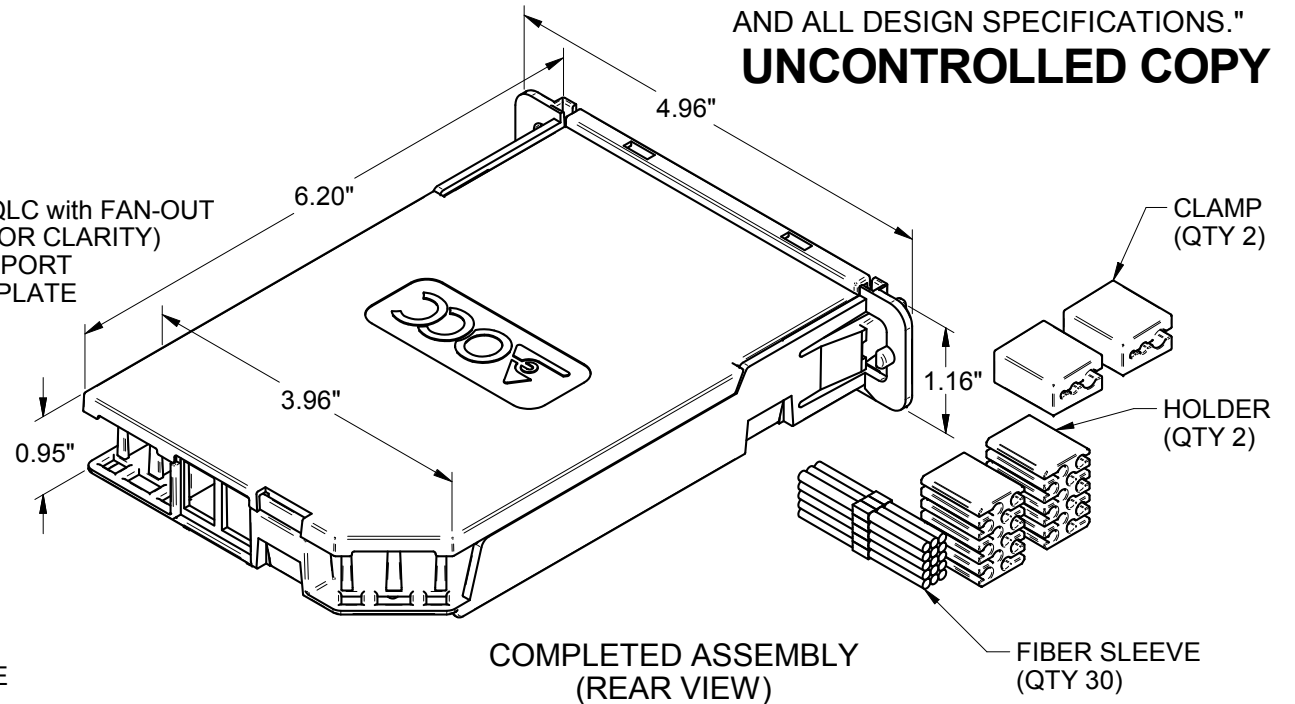
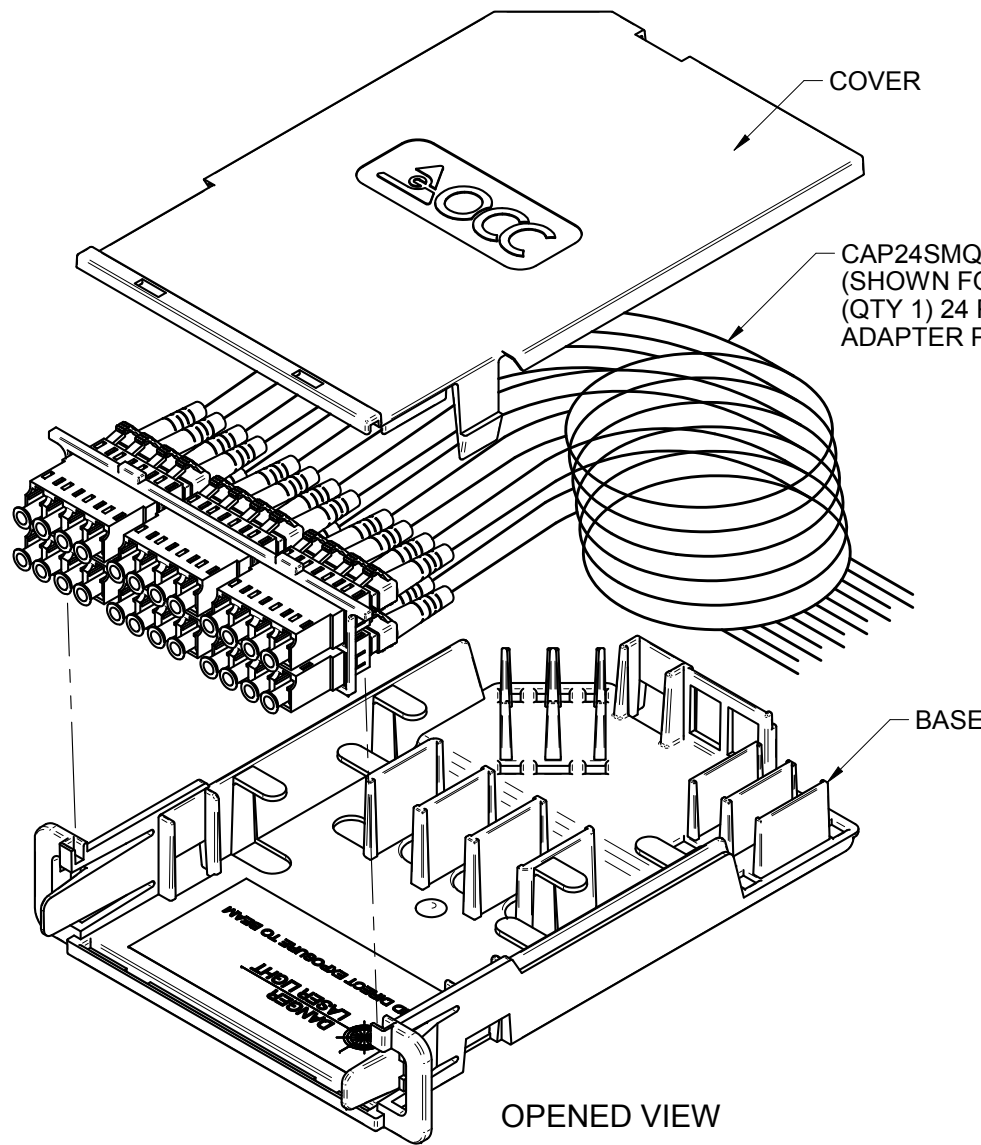

COMPLETED ASSEMBLY
(REAR VIEW)

FSCSA24QLCP	SPLICE CASSETTE, B & C, LC X 12, QUAD, APC, SPLICE, WITH FAN-OUT
FSCS824QLCP	SPLICE CASSETTE, B & C, LC X 12, QUAD, SM, SPLICE, WITH FAN-OUT
FSCS524QLCP	SPLICE CASSETTE, B & C, LC X 12, QUAD, 50µm OM5, SPLICE, WITH FAN-OUT
FSCS424QLCP	SPLICE CASSETTE, B & C, LC X 12, QUAD, 50µm OM4, SPLICE, WITH FAN-OUT
FSCS324QLCP	SPLICE CASSETTE, B & C, LC X 12, QUAD 50µm OM3, SPLICE, WITH FAN-OUT
FSCS224QLCP	SPLICE CASSETTE, B & C, LC X 12, QUAD, 50µm OM2, SPLICE, WITH FAN-OUT
FSCS124QLCP	SPLICE CASSETTE, B & C, LC X 12, QUAD, 62.5µm OM1, SPLICE, WITH FAN-OUT
OCC PART NO.	DESCRIPTION

UNCONTROLLED COPY

UNLESS OTHERWISE SPECIFIED
DIMENSIONS ARE IN INCHES.
TOLERANCES: FRACTIONS ±1/32"
ANGLES ±1/2°
3 PLACE DECIMALS ±.005"
2 PLACE DECIMALS ±.01"



5290 Concourse Drive
Roanoke, VA 24019
Phone: 800-622-7711
Fax: 540-265-0724
www.occfiber.com

NOTES: UNLESS OTHERWISE SPECIFIED.

1. INCLUDES SUPPLIED HARDWARE:

- (30) SLEEVE, FIBER PROTECTION, 40mm LONG
- (2) CLAMP, CABLE ENTRY, SPLICE CASSETTE
- (2) HOLDER, 12 SPLICE SLEEVE, SPLICE CASSETTE

THIRD ANGLE PROJECTION	
CRITICAL DIMENSION CODE	(F) = FUNCTION (M) = MATING (A) = AUDIT

MATERIAL	SEE BILL OF MATERIAL
FINISH	SEE NOTES

DRAWN	D.HOLBERT	DATE	11/18/19
CHECKED	J.HOWE	DATE	11/21/19
ENGINEER	J.YANIK	DATE	11/18/19
APPROVED	D.INGLE	DATE	11/21/19
PREVIOUS DWG			
NEXT DWG			

DWG TITLE			
CUSTOMER DRAWING, SPLICE CASSETTE ASSEMBLY, LC ADAPTER PLATE (LOADED)			
SIZE	DWG NO.	REV	
B	C113360	A	
FILENAME	C113360A.dft	SCALE:	NONE
SHEET	1 OF 1		