

NOTES: UNLESS OTHERWISE SPECIFIED.

1. OCC RESERVES THE PRIVILEGE OF COMPONENT(S) UPGRADES TO MEET DESIGN NEEDS, AS NECESSARY.

"OPTICAL CABLE CORPORATION (OCC) RESERVES THE RIGHT TO REVISE ANY AND ALL DESIGN SPECIFICATIONS."

UNCONTROLLED COPY

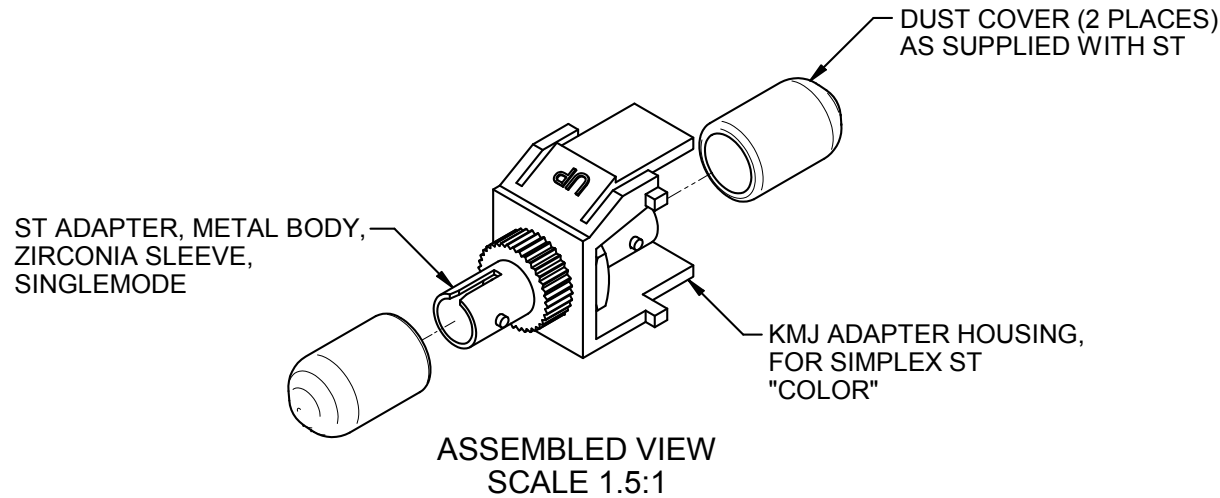

ASSEMBLED VIEW
SCALE 1.5:1

OCC PART NO.	DESCRIPTION
AKSTS12	AXCESS ADAPTER, KMJ, ST, SM, BRIGHT WHITE
AKSTS11	AXCESS ADAPTER, KMJ, ST, SM, BROWN
AKSTS10	AXCESS ADAPTER, KMJ, ST, SM, PURPLE
AKSTS09	AXCESS ADAPTER, KMJ, ST, SM, YELLOW
AKSTS08	AXCESS ADAPTER, KMJ, ST, SM, ORANGE
AKSTS07	AXCESS ADAPTER, KMJ, ST, SM, WHITE
AKSTS06	AXCESS ADAPTER, KMJ, ST, SM, GREY
AKSTS05	AXCESS ADAPTER, KMJ, ST, SM, BLUE
AKSTS04	AXCESS ADAPTER, KMJ, ST, SM, GREEN
AKSTS03	AXCESS ADAPTER, KMJ, ST, SM, RED
AKSTS02	AXCESS ADAPTER, KMJ, ST, SM, BLACK
AKSTS01	AXCESS ADAPTER, KMJ, ST, SM, OFF. WHITE
AKSTS00	AXCESS ADAPTER, KMJ, ST, SM, ELEC. IVORY

UNLESS OTHERWISE SPECIFIED DIMENSIONS ARE IN INCHES
TOLERANCES:
FRACTIONS ±1/32"
ANGLES ±1/2°
3 PLACE DECIMALS ±.005"
2 PLACE DECIMALS ±.01"

THIS DRAWING AND THE DESIGN SHOWN ARE THE PROPERTY OF OPTICAL CABLE CORPORATION AND MAY NOT BE USED AS THE BASIS FOR MANUFACTURE OR SALE WITHOUT SPECIFIC WRITTEN PERMISSION OF OPTICAL CABLE CORPORATION.



33 Superior Way
Swannanoa, NC 28778
Phone: 828-298-2260
Fax: 828-298-2487
www.occfiber.com

THIRD ANGLE PROJECTION

CRITICAL DIMENSION CODE
Ⓢ = FUNCTION
Ⓜ = MATING
Ⓐ = AUDIT

MATERIAL VARIOUS
SEE BILL OF MATERIAL

FINISH N/A

DRAWN D.A.HOLBERT	DATE 11/1/01
CHECKED J.HOWE	DATE 1/23/02
ENGINEER J.YANIK	DATE 11/1/01
APPROVED J.CALLOWAY	DATE 6/30/21
PREVIOUS DWG	
NEXT DWG	

DWG TITLE ASSY, AXCESS ADAPTER, KMJ, ST, SINGLEMODE		SIZE B	DWG NO. C103161	REV E
FILENAME	C103161E.dft	SCALE:	1.5:1	SHEET
				1 OF 1

PROPRIETARY AND CONFIDENTIAL