

NOTES: UNLESS OTHERWISE SPECIFIED.

1. OCC RESERVES THE PRIVILEGE OF COMPONENT(S) UPGRADES TO MEET DESIGN NEEDS, AS NECESSARY.

"OPTICAL CABLE CORPORATION (OCC) RESERVES THE RIGHT TO REVISE ANY AND ALL DESIGN SPECIFICATIONS."

UNCONTROLLED COPY

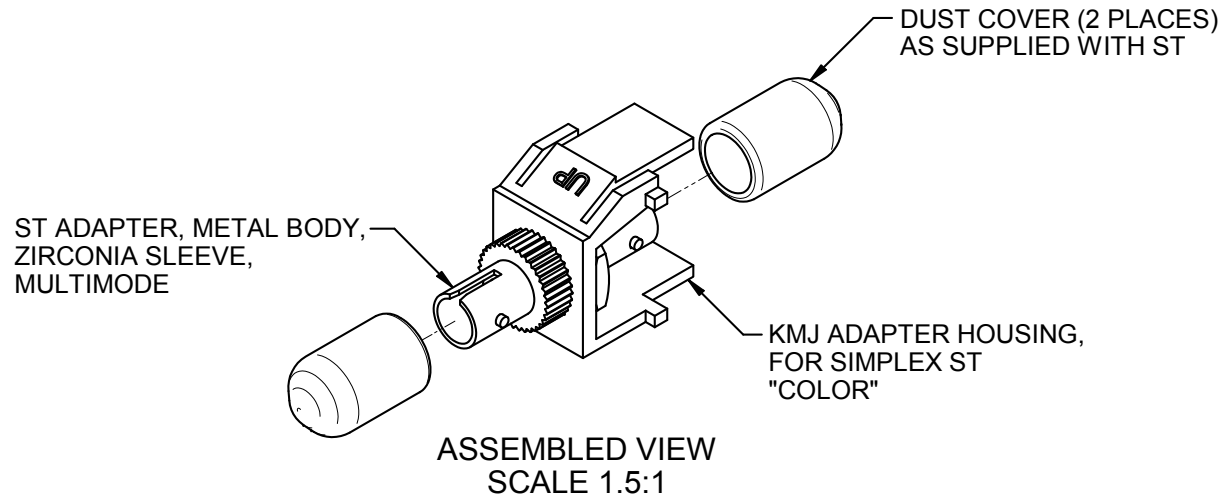

ASSEMBLED VIEW
SCALE 1.5:1

OCC PART NO.	DESCRIPTION
AKSTM12	AXCESS ADAPTER, KMJ, ST, MM, BRIGHT WHITE
AKSTM11	AXCESS ADAPTER, KMJ, ST, MM, BROWN
AKSTM10	AXCESS ADAPTER, KMJ, ST, MM, PURPLE
AKSTM09	AXCESS ADAPTER, KMJ, ST, MM, YELLOW
AKSTM08	AXCESS ADAPTER, KMJ, ST, MM, ORANGE
AKSTM07	AXCESS ADAPTER, KMJ, ST, MM, WHITE
AKSTM06	AXCESS ADAPTER, KMJ, ST, MM, GREY
AKSTM05	AXCESS ADAPTER, KMJ, ST, MM, BLUE
AKSTM04	AXCESS ADAPTER, KMJ, ST, MM, GREEN
AKSTM03	AXCESS ADAPTER, KMJ, ST, MM, RED
AKSTM02	AXCESS ADAPTER, KMJ, ST, MM, BLACK
AKSTM01	AXCESS ADAPTER, KMJ, ST, MM, OFF. WHITE
AKSTM00	AXCESS ADAPTER, KMJ, ST, MM, ELEC. IVORY

UNLESS OTHERWISE SPECIFIED
DIMENSIONS ARE IN INCHES
TOLERANCES:
FRACTIONS ±1/32"
ANGLES ±1/2°
3 PLACE DECIMALS ±.005"
2 PLACE DECIMALS ±.01"

THIS DRAWING AND THE DESIGN SHOWN ARE THE PROPERTY OF OPTICAL CABLE CORPORATION AND MAY NOT BE USED AS THE BASIS FOR MANUFACTURE OR SALE WITHOUT SPECIFIC WRITTEN PERMISSION OF OPTICAL CABLE CORPORATION.



33 Superior Way
Swannanoa, NC 28778
Phone: 828-298-2260
Fax: 828-298-2487
www.occfiber.com

THIRD ANGLE PROJECTION
CRITICAL DIMENSION CODE
Ⓢ = FUNCTION
Ⓜ = MATING
Ⓐ = AUDIT

MATERIAL VARIOUS
SEE BILL OF MATERIAL
FINISH N/A

DRAWN	D.A.HOLBERT	DATE	1/25/05
CHECKED	J.HOWE	DATE	1/31/05
ENGINEER	J.YANIK	DATE	1/25/05
APPROVED	J.CALLOWAY	DATE	6/30/21
PREVIOUS DWG			
NEXT DWG			

DWG TITLE			REV
ASSY, AXCESS ADAPTER, KMJ, ST, MULTIMODE			C
SIZE	DWG NO.	REV	
B	C107106	C	
SCALE:	1.5:1	SHEET	1 OF 1

PROPRIETARY AND CONFIDENTIAL