

"OPTICAL CABLE CORPORATION (OCC)  
RESERVES THE RIGHT TO REVISE ANY  
AND ALL DESIGN SPECIFICATIONS."

**UNCONTROLLED COPY**

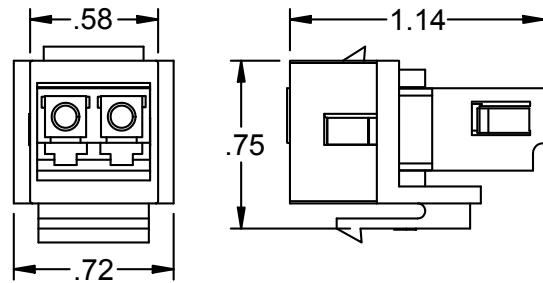

ASSEMBLY VIEW

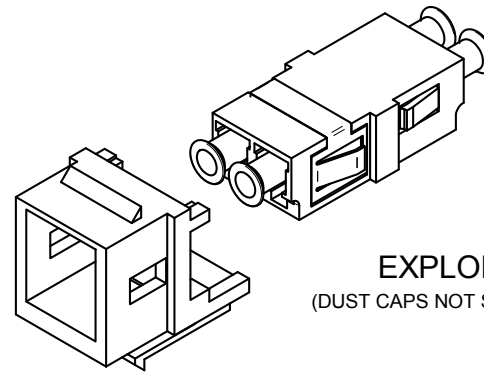

EXPLODED VIEW  
(DUST CAPS NOT SHOWN, FOR CLARITY)

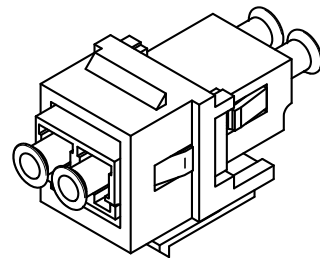

COMPLETED ASSEMBLY

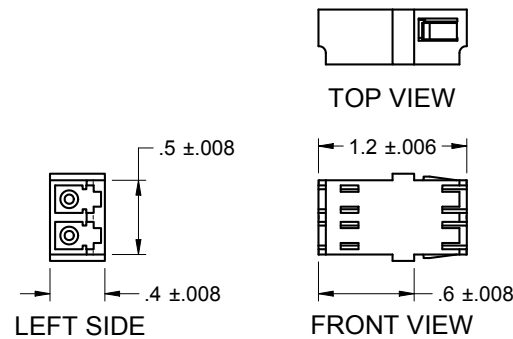

TOP VIEW

LEFT SIDE

FRONT VIEW

NOTES: UNLESS OTHERWISE SPECIFIED.

1. EACH FIBER ADAPTER KIT IS SUPPLIED WITH COMPONENTS SHOWN.
2. OCC RESERVES THE PRIVILEGE OF COMPONENT(S) UPGRADES TO MEET DESIGN NEEDS, AS NECESSARY.

AKDLCA12	ASSY, ADAPTER, KMJ, DUAL LC, APC, BRIGHT WHITE, COMMERCIAL
AKDLCA11	ASSY, ADAPTER, KMJ, DUAL LC, APC, BROWN, COMMERCIAL
AKDLCA10	ASSY, ADAPTER, KMJ, DUAL LC, APC, PURPLE, COMMERCIAL
AKDLCA09	ASSY, ADAPTER, KMJ, DUAL LC, APC, YELLOW, COMMERCIAL
AKDLCA08	ASSY, ADAPTER, KMJ, DUAL LC, APC, ORANGE, COMMERCIAL
AKDLCA07	ASSY, ADAPTER, KMJ, DUAL LC, APC, WHITE, COMMERCIAL
AKDLCA06	ASSY, ADAPTER, KMJ, DUAL LC, APC, GREY, COMMERCIAL
AKDLCA05	ASSY, ADAPTER, KMJ, DUAL LC, APC, BLUE, COMMERCIAL
AKDLCA04	ASSY, ADAPTER, KMJ, DUAL LC, APC, GREEN, COMMERCIAL
AKDLCA03	ASSY, ADAPTER, KMJ, DUAL LC, APC, RED, COMMERCIAL
AKDLCA02	ASSY, ADAPTER, KMJ, DUAL LC, APC, BLACK, COMMERCIAL
AKDLCA01	ASSY, ADAPTER, KMJ, DUAL LC, APC, OFFICE WHITE, COMMERCIAL
AKDLCA00	ASSY, ADAPTER, KMJ, DUAL LC, APC, ELEC. IVORY, COMMERCIAL

OCC PART NO.	DESCRIPTION
UNLESS OTHERWISE SPECIFIED DIMENSIONS ARE IN INCHES. TOLERANCES: FRACTIONS ±1/32" ANGLES ±1/2° 3 PLACE DECIMALS ±.005" 2 PLACE DECIMALS ±.01"	
THIS DRAWING AND THE DESIGN SHOWN ARE THE PROPERTY OF OPTICAL CABLE CORPORATION AND MAY NOT BE USED AS THE BASIS FOR MANUFACTURE OR SALE WITHOUT SPECIFIC WRITTEN PERMISSION OF OPTICAL CABLE CORPORATION.	
DRAWN D.A.HOLBERT	DATE 3/2/17
CHECKED J.HOWE	DATE 3/13/17
ENGINEER J.YANIK	DATE 3/2/17
APPROVED J.CALLOWAY	DATE 7/27/21
PREVIOUS DWG	
NEXT DWG	FILENAME C112731C.dft

<b>OCC</b> OPTICAL CABLE CORPORATION		33 Superior Way Swannanoa, NC 28778 Phone: 828-298-2260 Fax: 828-298-2487 www.occfiber.com	
DWG TITLE <b>ASSY, ADAPTER, KMJ, DUAL LC, SM/APC, COMMERCIAL</b>			
SIZE <b>B</b>	DWG NO. <b>C112731</b>	REV <b>C</b>	
SCALE: NONE		SHEET 1 OF 1	

THIRD ANGLE PROJECTION	
CRITICAL DIMENSION CODE	FINISH SEE NOTES
(F) = FUNCTION	
(M) = MATING	
(A) = AUDIT	

PROPRIETARY AND CONFIDENTIAL