

# SPECIFICATIONS

## FEATURES/MATERIALS:

CUSTOM ACCESS ADAPTERS ARE AVAILABLE IN A WIDE VARIETY OF COLORS.

ACCESS ADAPTERS ARE CONSTRUCTED OF HIGH-IMPACT SELF EXTINGUISHING, UL RATED 94V-0

OPTIONAL COLORS CAN BE ORDERED BY REPLACING "XX" WITH COLOR CODE.  
EXAMPLE: AADLCA02 = BLACK

SUBJECT TO AVAILABILITY, LEAD-TIMES AND MINIMUMS MAY APPLY.

## ACCESS ADAPTER COLOR CHART

00 ELECTRICAL IVORY	07 WHITE
01 OFFICE WHITE	08 ORANGE
02 BLACK	09 YELLOW
03 RED	10 PURPLE
04 GREEN	11 BROWN
05 BLUE	12 BRIGHT WHITE
06 DATA GRAY	

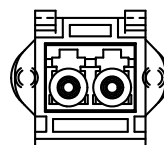

FRONT VIEW  
P/N AADLCAxx

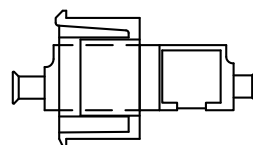

RIGHT SIDE

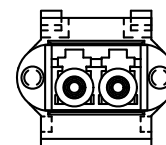

BACK VIEW

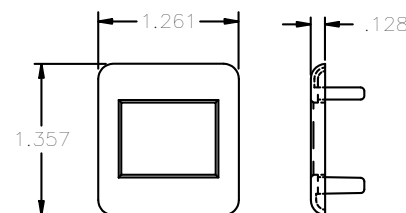

LC/SC BEZEL

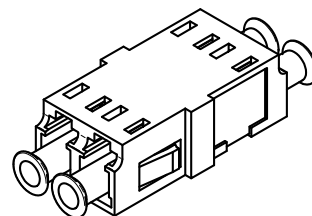

EXPLODED VIEW  
(SHOWN FOR CLARITY)  
ISOMETRIC VIEW  
P/N AADLCAxx

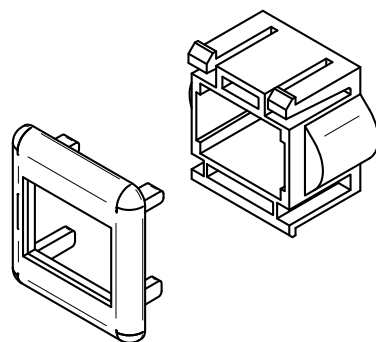

NOTES: UNLESS OTHERWISE SPECIFIED.

- EACH FIBER ADAPTER KIT IS SUPPLIED WITH COMPONENTS SHOWN.
- ADAPTER SPECIFICATIONS (SINGLEMODE) FOR APC  
INSERTION LOSS (AVERAGE): ZIRCONIA CERAMIC SLEEVE:  $\leq 0.2$  dB MAX.  
SLEEVE/FERRULE WITHDRAWAL FORCE: 2.0N ~ 5.9N (200gf ~ 600gf)

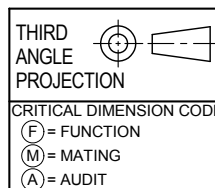

MATERIAL SEE BILL OF MATERIAL	FINISH SEE NOTES
----------------------------------	---------------------

OCC PART NO.	DESCRIPTION
AADLCA12	ASSY, ACCESS ADAPTER, DUPLEX LCAPC, SM, BRT. WHITE
AADLCA11	ASSY, ACCESS ADAPTER, DUPLEX LCAPC, SM, BROWN
AADLCA10	ASSY, ACCESS ADAPTER, DUPLEX LCAPC, SM, PURPLE
AADLCA09	ASSY, ACCESS ADAPTER, DUPLEX LCAPC, SM, YELLOW
AADLCA08	ASSY, ACCESS ADAPTER, DUPLEX LCAPC, SM, ORANGE
AADLCA07	ASSY, ACCESS ADAPTER, DUPLEX LCAPC, SM, WHITE
AADLCA06	ASSY, ACCESS ADAPTER, DUPLEX LCAPC, SM, GREY
AADLCA05	ASSY, ACCESS ADAPTER, DUPLEX LCAPC, SM, BLUE
AADLCA04	ASSY, ACCESS ADAPTER, DUPLEX LCAPC, SM, GREEN
AADLCA03	ASSY, ACCESS ADAPTER, DUPLEX LCAPC, SM, RED
AADLCA02	ASSY, ACCESS ADAPTER, DUPLEX LCAPC, SM, BLACK
AADLCA01	ASSY, ACCESS ADAPTER, DUPLEX LCAPC, SM, OFF. WHITE
AADLCA00	ASSY, ACCESS ADAPTER, DUPLEX LCAPC, SM, ELEC. IVORY

### UNCONTROLLED COPY

UNLESS OTHERWISE SPECIFIED DIMENSIONS ARE IN INCHES. TOLERANCES: FRACTIONS $\pm 1/32"$ ANGLES $\pm 1/2^\circ$ 3 PLACE DECIMALS $\pm 0.005"$ 2 PLACE DECIMALS $\pm 0.01"$	THIS DRAWING AND THE DESIGN SHOWN ARE THE PROPERTY OF OPTICAL CABLE CORPORATION AND MAY NOT BE USED AS THE BASIS FOR MANUFACTURE OR SALE WITHOUT SPECIFIC WRITTEN PERMISSION OF OPTICAL CABLE CORPORATION.
DRAWN D.A.HOLBERT	DATE 9/4/03
CHECKED J.HOWE	DATE 8/25/04
ENGINEER J.YANIK	DATE 9/4/03
APPROVED J.CALLOWAY	DATE 6/11/23
PREVIOUS DWG	
NEXT DWG	FILENAME C113788G.dft

### CUSTOMER DRAWING



33 Superior Way  
Swannanoa, NC 28778  
Phone: 828-298-2260  
Fax: 828-298-2487  
www.occfiber.com

DWG TITLE <b>ASSEMBLY, LC DUPLEX, ACCESS ADAPTER, SM/APC</b>		SIZE <b>B</b>	DWG NO. <b>C113788</b>	REV <b>G</b>
SCALE:	NONE	SHEET	1 OF 1	

"OPTICAL CABLE CORPORATION (OCC) RESERVES THE RIGHT TO REVISE ANY AND ALL DESIGN SPECIFICATIONS."

**UNCONTROLLED COPY**

PROPRIETARY AND CONFIDENTIAL