

REVISION HISTORY			
REV	DESCRIPTION	DATE	APPROVED
A	Initial Release	5/22/2023	RP

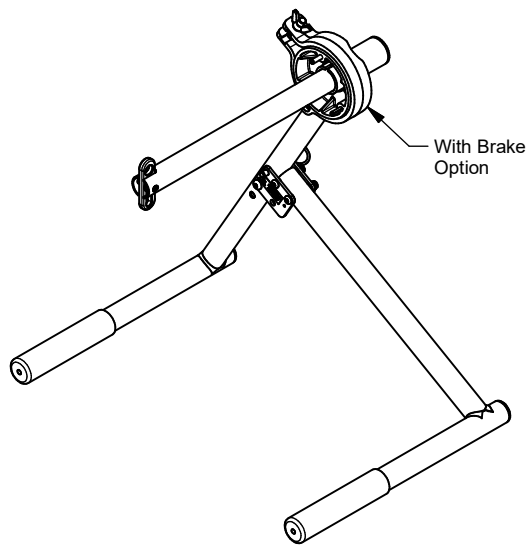

PART NUMBER CONFIGURATOR									
PART NUMBER	Size Option			Brake Option		Paint Type		Color Option	
	xxxx	"A"	Description	b	Description	p	Description	c	Description
ATD-xxxx-b-p-c	0100	4.5"	100m	0	No	1	Powder Coat	T	Tan
	0300	7.2"	300m	1	Yes	2	CARC	G	Green
	0500	10.2"	500m					B	Black

SAMPLE PART NUMBER
ATD-0500-1-1-T
Tripod, EZ-Fold, AFO-0500 Reel, with Brake, Powder coat Tan

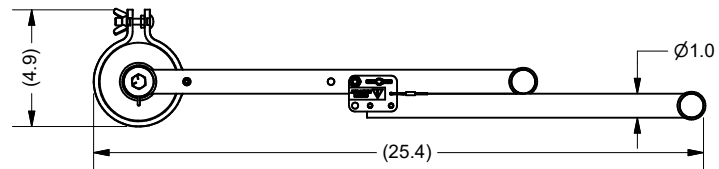
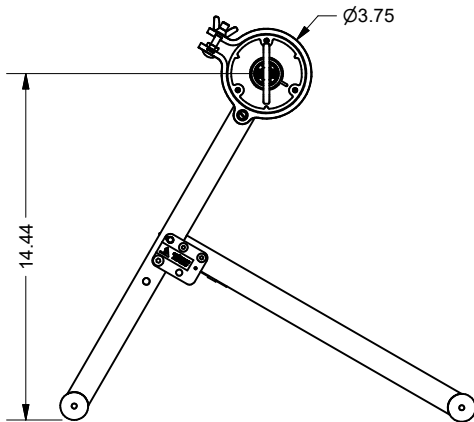
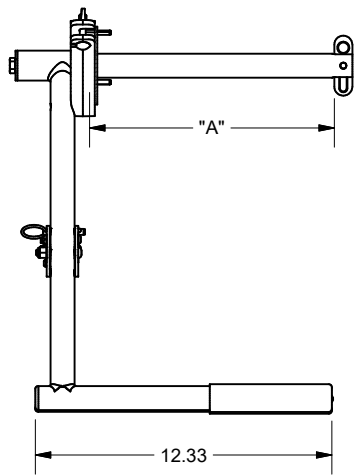

COLLAPSED VIEW

NOTES: UNLESS OTHERWISE SPECIFIED

- MATERIAL:
Frame: Mild Steel
Brake Components: Thermoplastic
Hardware: Stainless Steel
- FINISH: Per Configuration
- WEIGHT: 4.2 to 4.7 lbs per Configuration

DRAWN rpenumatcha	5/22/2023	 OPTICAL CABLE CORPORATION FORMERLY APPLIED OPTICAL SYSTEMS	1700 Capital Ave., Suite 150 Plano, TX-75074 (972)509-1500 www.occfiber.com CAGE CODE: 335J8	
APPROVED RP	5/24/2023		FORMERLY APPLIED OPTICAL SYSTEMS	
PRODUCT DRAWING		TITLE		
ALL DIMENSIONS ARE IN INCHES DO NOT SCALE DRAWING		Tripod, EZ-Fold, for MARS REEL		
DWG NO	PD-ATD-xxxx-x-x-x	REV	A	SHEET
				1 OF 1

THIS DOCUMENT IS THE PROPERTY OF OPTICAL CABLE CORPORATION AND CONTAINS PROPRIETARY INFORMATION AND SHALL NOT BE DISCLOSED TO OTHERS OR DUPLICATED IN PART OR FULL OR USED FOR ANYOTHER PURPOSES OTHER THAN IN SUPPORT OF OUR VENDOR/PURCHASER RELATIONSHIP